

5519 (supersedes 5485)–0208–R4

Technical Data

Specifications & Capacities

ATC 3250

Telescopic Boom All Terrain Crane
250 ton (220.0 metric ton)

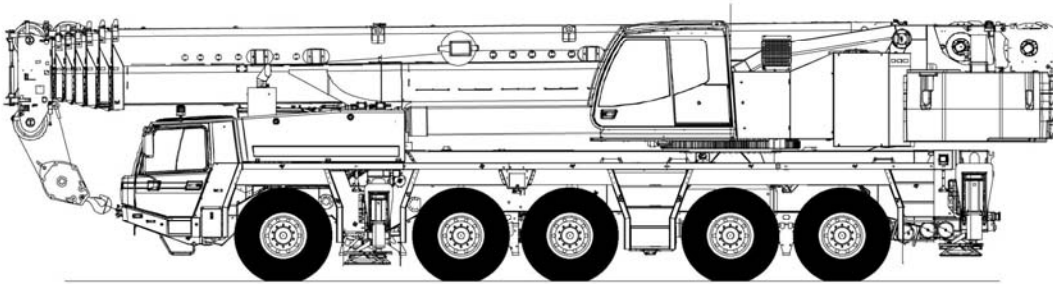

CAUTION: This material is supplied for reference use only. Operator must refer to in-cab Crane Rating Manual and Operator's Manual to determine allowable crane lifting capacities and assembly and operating procedures.

Link-Belt Cranes

ATC-3250

5519 (supersedes 5485) – 0208 – R4

Table Of Contents

Boom, Attachments, and Upper Structure	1
Boom	1
Boom Head	1
Boom Elevation	1
Auxiliary Lifting Sheave – Optional	1
Heavy Duty Lifting Sheave Package – Optional	1
Hook Blocks and Balls – Optional	1
Fly – Optional	1
Fly Inserts – Optional	1
Upper Operator’s Cab and Controls	2
Swing	3
Central Lubrication System	3
Electrical	3
Hydraulic System	3
Pump Drive	3
Fuel Tank	3
Engine	3
Load Hoist System	4
Main and Auxiliary (Optional) Winches	4
Counterweight	4
Carrier	6
General	6
Outriggers	6
Steering and Axles	6
Suspension	6
Ground Control Outrigger/Suspension Controls	7
Tires and Wheels	7
Brakes	7
Central Lubrication System	7
Electrical	7
Engine	7
Transmission	7
Fuel Tank	7
Hydraulic System	7
Cab and Controls	8
Additional Equipment	8
Carrier Speeds and Gradeability	9
Axle Loads – English	10
Axle Loads – Metric	11
Axle Loads with 2–Axle or 3–Axle Boom Dolly (3rd Axle Down) – English	12
Axle Loads with 2–Axle or 3–Axle Boom Dolly (3rd Axle Down) – Metric	13
Axle Loads with 2–Axle or 3–Axle Boom Dolly (3rd Axle Lifted) – English	14
Axle Loads with 2–Axle or 3–Axle Boom Dolly (3rd Axle Lifted) – Metric	15
General Dimensions	16

ATC–3250

Link–Belt Cranes

Working Range Diagram	17
Boom Extend Modes	18
Main Boom Lift Capacity Charts	19
156,527 lb Counterweight – Fully Extended Outriggers – 360° Rotation	19
103,616 lb Counterweight – Fully Extended Outriggers – 360° Rotation	20
77,161 lb Counterweight – Fully Extended Outriggers – 360° Rotation	21
51,808 lb Counterweight – Fully Extended Outriggers – 360° Rotation	22
26,455 lb Counterweight – Fully Extended Outriggers – 360° Rotation	23
0 lb Counterweight – Fully Extended Outriggers – 360° Rotation	24
Fly Attachment Lift Capacity Charts – Optional	25
156,527 lb Counterweight – Fully Extended Outriggers – 360° Rotation	25
103,616 lb Counterweight – Fully Extended Outriggers – 360° Rotation	30
77,161 lb Counterweight – Fully Extended Outriggers – 360° Rotation	35
51,808 lb Counterweight – Fully Extended Outriggers – 360° Rotation	40

Boom, Attachments, and Upper Structure

■ Boom

Design – Seven section, formed construction of extra high tensile steel consisting of one base section and six telescoping sections. The two plate design of each section has multiple longitudinal bends for superior strength. Each telescoping section extends independently by means of one double-acting, single stage hydraulic cylinder with an integrated holding valve.

Boom

- 43.3–223.1 ft (13.2–68.0m) seven section boom
- Four pinned positions of 0%, 46%, 92%, and 100% on each boom section provide thirty-eight extend combinations for superior capacities when varying the extension of the telescoping sections, controlled from the operator's cab.
- Integral boom dolly connection
- Mechanical boom angle indicator
- Wind speed indicator
- Maximum tip height for the following boom lengths are:

Boom Length (Pinned Positions)		Tip Height	
ft	m	ft	m
223.1	68.0	234.4	71.5
208.0	63.4	219.4	66.9
194.2	59.2	205.9	62.8
180.4	55.0	192.2	58.6
167.0	50.9	178.6	54.4
153.2	46.7	164.9	50.3
139.4	42.5	151.3	46.1
125.7	38.3	137.6	41.9
111.9	34.1	124.0	37.8
98.4	30.0	110.3	33.6
84.6	25.8	96.7	29.3
70.9	21.6	83.0	25.3
57.1	17.4	69.4	21.2
43.3	13.2	55.8	17.0

Boom Head

- Seven 18.2 in (46.2cm) root diameter nylon sheaves to handle up to fourteen parts of line
- Easily removable wire rope guards
- Rope dead end lugs on one side of the boom head
- Boom head is designed for quick-reeve of the hook block

Boom Elevation

- One double acting hydraulic cylinder with integral holding valve
- Boom elevation: -1.5° to 84°
- **Load Comp** – Load compensator maintains a consistent radius during load lift-off by automatically elevating boom hoist cylinder. Operated by a switch from the operator's cab.

Auxiliary Lifting Sheave – Optional

- Single 18.2 in (46.2cm) root diameter nylon sheave
- Easily removable wire rope guards
- Does not affect erection of the fly or use of the main head sheaves

Heavy Duty Lifting Sheave Package – Optional

- Two 18.2 in (46.2cm) root diameter nylon sheaves
- Easily removable wire rope guards
- Does not affect erection of the fly or use of the main head sheaves
- Necessary to achieve greater than 15 parts of line lifts

Hook Blocks and Balls – Optional

- 27.6 ton (25.0mt) 1 sheave quick-reeve hook block with safety latch
- 88.2 ton (80.0mt) 5 sheave quick-reeve hook block with safety latch
- 140 ton (127.0mt) 7 sheave quick-reeve hook block with safety latch
- 200 ton (181.4mt) 11 sheave quick-reeve hook block with safety latch
- 11 ton (10.0mt) swivel hook ball with safety latch

Fly – Optional

- 17.7 ft–43.3 ft (5.4–13.2m) two piece lattice fly, stowable, offsettable to 0° , 20° , and 40° . Maximum tip height is 279.5 ft (85.2m).

Fly Inserts – Optional

- Four 19.7 ft (6.0m) lattice inserts to be mounted between the 17.7 ft (5.4m) lattice fly base and the 25.6 ft (7.8m) lattice fly tip option. Maximum tip heights for the following fly lengths are:

Fly Length		Tip Height	
ft	m	ft	m
63.0	19.2	298.9	91.1
82.7	25.2	318.6	97.1
102.4	31.2	338.3	103.1
122.1	37.2	358.0	109.1

■ Upper Operator's Cab and Controls

Environmental Cab – Fully enclosed, one person cab of composite (fiberglass and steel) structure with acoustical insulation. Equipped with:

- Tilting interior where the operator's seat, joystick controllers, floor controls and pedals, and main console tilt within the cab
- Tinted and tempered glass windows
- Extra–large power up/power down front window with windshield wiper and washer
- Fixed roof window with windshield wiper
- Sliding left side door with large fixed window
- Fold out rear window for ventilation
- Fixed right side window
- Six way adjustable, cushioned seat with headrests, adjustable lumbar support, and seat belt
- Engine dependent warm–water heater with air ducts for front windshield defroster and cab floor
- AM/FM stereo with single disc CD player
- 12 volt and 24 volt power connections
- Engine hourmeter
- Rated capacity limiter override
- Adjustable sun visor
- Dome light
- Cup holder
- Fire extinguisher
- Left side viewing mirror
- Integral recessed cabwalks
- One position travel swing lock

Air Conditioning – Integral with cab heating system utilizing the same ventilation outlets

Armrest Controls – Two dual axis electronic joystick controllers for:

- Swing
- Boom hoist
- Boom telescope
- Main front winch
- Auxiliary rear winch – optional
- Drum rotation indicator(s)
- Winch high/low speed and disable switch(es)
- Free swing/automatic swing brake switch
- Auxiliary winch/telescope switch
- High speed function button
- Warning horn

Foot Controls

- Swing brake
- Engine throttle

Front Main Console – Controls and indicators for:

- Emergency shut down switch
- Central warning indication
- Outrigger controls

Right Side Console – Controls and indicators for:

- Auxiliary winch disable switch
- Swing override switch
- Drum rotation indicator activation switch
- Telescopic override switches
- Engine shutdown switch
- Anti–two block override switch

Right Side Overhead Console – Controls and indicators for:

- Central lubrication system switch
- Boom and cab floodlight switches
- Top windshield wiper switch
- Front windshield wiper and washer switch
- Power up/power down front windshield switch
- Tilting interior switch
- Battery main shutoff switch
- Supplementary heater controls

Cockpit Graphic Control (CGC) – Ergonomically positioned on the front main console, digital instrumentation, and control for crane operations including:

- Engine coolant temperature
- Electronic bubble level and levelness readout
- CAN–BUS diagnostic and engine electronic fault indicator
- Swing lock indicator
- Hydraulic oil and air cleaner filter indicator
- Hydraulic oil temperature
- Low engine oil pressure indicator
- Low voltage indicator
- Fuel level
- Carrier engine start and stop
- Carrier park brake indicator
- Suspension lock indicator
- Axle lift indicator
- Outrigger operation
- Outrigger force readout – optional

Rated Capacity Limiter – Graphic audio–visual warning system integrated into the front main console with anti–two block and function limiter. Operating data available includes:

- Crane configuration
- Boom length and angle
- Boom head height
- Allowed load and % of allowed load
- Boom angle
- Radius of load
- Actual load
- Wind speed
- Operator settable alarms (include):
 - Maximum and minimum boom angles
 - Maximum and minimum tip height
 - Maximum boom length
 - Left/right swing positions
 - Work radius

■ Swing

Motor/Planetary – Bi-directional hydraulic swing motor mounted to a planetary reduction unit for 360° continuous smooth swing at 1.8 rpm. Free swing capable when controller within the operator's cab is in the neutral position.

Swing Park Brake – 360°, electric over hydraulic, (spring applied/hydraulic released) multi-disc brake mounted on the reduction unit. Operated by a switch from the operator's cab.

Swing Brake – 360°, foot operated, hydraulic applied disc brake mounted to the reduction unit.

Swing Lock – One-position swing lock (boom over rear) operated from the operator's cab.

Automatic Swing Brake Mode – Swing brake applies when controller within the operator's cab is in the neutral position. Operated by a switch from the operator's cab.

360° Positive Swing Lock – Optional – Meets New York City requirement.

■ Central Lubrication System

Automated lubrication unit that injects grease into the turntable bearing, boom hoist cylinder pins, boom foot pin, and the main (front) and auxiliary (rear) winch. Operated by a switch from the operator's cab.

■ Electrical

Two batteries provide 24-volt operation and starting. CAN bus wiring and components, and integral self-test CSS (Control & Service System).

Swing Alarm – Audio warning device signals when the upper is swinging.

Lights

- Two working lights on front of the cab
- One rotating amber beacon on the right side of the main winch
- One boom floodlight on the boom base section
- Two side marker lights on the boom head

■ Hydraulic System

Main Pumps

- Two variable displacement piston pumps for the main and auxiliary winches, boom hoist and telescope
- One fixed displacement piston pump for swing
- One fixed displacement gear pump for pilot pressure
- One fixed displacement gear pump for counterweight
- The upper engine powers the pumps. Combined pump capacity of 178.2 gpm (674Lpm).
- Remote mounted, auxiliary hydraulic oil cooler

Pump Control "fine inching" Mode – Special fine metering pump settings, selectable from the operator's cab, allows very slow movements to the main and auxiliary winches, boom hoist, and swing for precision work.

Pump Control "high speed" Mode – Boosts hydraulic oil flow by combining the two variable displacement piston pumps for the main and auxiliary winches, boom hoist up, and telescope extend. Operated by a button on the right joystick controller from the operator's cab.

Hydraulic Reservoir – 291 gal (1 100L) capacity equipped with sight level gauge. Diffusers built in for deaeration.

Filtration – One 12 micron, full flow, line filter in the control circuit. All oil is filtered prior to return to sump tank. Accessible for easy filter replacement.

Counterbalance Valves – All hoist motors, boom extend cylinders, and boom hoist cylinders are equipped with counterbalance valves to provide load lowering and prevents accidental load drop when hydraulic power is suddenly reduced.

Boom Hoist Float Valves – For transporting the boom over the rear of the crane with a boom dolly. Allows hydraulic oil within the boom hoist cylinder to flow between piston side and case side.

Swing Brake Release Valve – For transporting the boom over the rear of the crane with a boom dolly. Holds the 360° swing park brake in the release position allowing free rotation of the upperstructure.

■ Pump Drive

All functions are hydraulically powered allowing positive, precise control with independent or simultaneous operation of all functions.

■ Fuel Tank

One 66.0 gal (250L) capacity tank.

■ Engine

Specification	Mercedes Benz OM 906 LA
Numbers of cylinders	6
Cycle	4
Bore and Stroke: inch (mm)	4.02 x 5.12 (102x130)
Piston Displacement: in ³ (cm ³)	388.72 (6 374)
Max. Brake Horsepower: hp (kW)	185 (138) @ 1,800 rpm
Peak Torque: ft lb (Nm)	553 (750) @ 1,200 rpm
Alternator: volts – amps	24 – 30
Crankcase Capacity: qt (L)	30.64 (29)

• Webasto Engine/Cab Heater – Diesel fired heating unit that can be used for preheating of the engine, or for engine preheating combined with heating of the operator's cab.

Main (Front) and Auxiliary (Rear) Winches – 0.83 in (21mm) Rope										
Layer	Maximum Line Pull		Normal Line Speed		High Line Speed		Layer		Total	
	lb	kg	ft/min	m/min	ft/min	m/min	ft	m	ft	m
1	24,504	11 115	207	63.2	332	101.1	176	53.7	176	53.7
2	22,706	10 299	226	68.8	361	110.0	192	58.5	368	112.2
3	20,907	9 483	244	74.3	390	119.0	207	63.2	575	175.4
4	19,558	8 872	262	79.9	420	127.9	223	68.0	799	243.4
5	18,210	8 260	281	85.5	449	136.8	239	72.7	1,037	316.1
6	17,085	7 750	299	91.1	478	145.8	254	77.5	1,291	393.6
7	15,961	7 240	317	96.7	508	154.7	270	82.2	1,561	475.8

Wire Rope Application	Diameter		Type	Maximum Permissible Load	
	in	mm		lb	kg
Main (Front) Winch	0.83	21	16 x 7 rotation resistant – right lang lay	17,175	7 790
Auxiliary (Rear) Winch	0.83	21	16 x 7 rotation resistant – right lang lay	17,175	7 790

■ Load Hoist System

Main and Auxiliary (Optional) Winches

- Axial piston, constant displacement motors driven through planetary reduction unit for positive control under all load conditions
- Grooved lagging
- Power up/down mode of operation
- Third wrap indicator with function lockout
- Drum rotation indicator
- Wire rope with "Superstop" easy reeving system
- Drum diameter: 20.67 in (525mm)
- Rope diameter: 0.83 in (21mm)
- Rope length:
 - Main: 1,148 ft (350m)
 - Auxiliary: 1,148 ft (350m)

Integrated Third Wrap Indicator – Rated capacity limiter color display visually and audibly warns the operator when the wire rope is on the first/bottom layer and when the wire rope is down to the last three wraps.

Auxiliary winch can be removed by cranes' counterweight removal system.

■ Counterweight

Standard – Total of 156,520 lb (71 000kg) of total counterweight consisting of seven hydraulically removable counterweights. Assembled and disassembled by hydraulic cylinders controlled from the operator's cab with capacities for:

- 0 lb (0kg) counterweight
- 26,455 lb (12 000kg) counterweight
- 51,808 lb (23 500kg) counterweight*
- 77,161 lb (35 000kg) counterweight*
- 103,616 lb (47 000kg) counterweight*
- 156,527 lb (71 000kg) counterweight**

Low speed jobsite travel is offered for these counterweight configurations and a boom dolly or boom trailer may be required for on-highway travel.

* Overall width of the crane increases to 15 ft 1 in (4.6m) for this counterweight configuration.

** Overall width of the crane increases to 18 ft 5 in (5.6m) for this counterweight configuration.

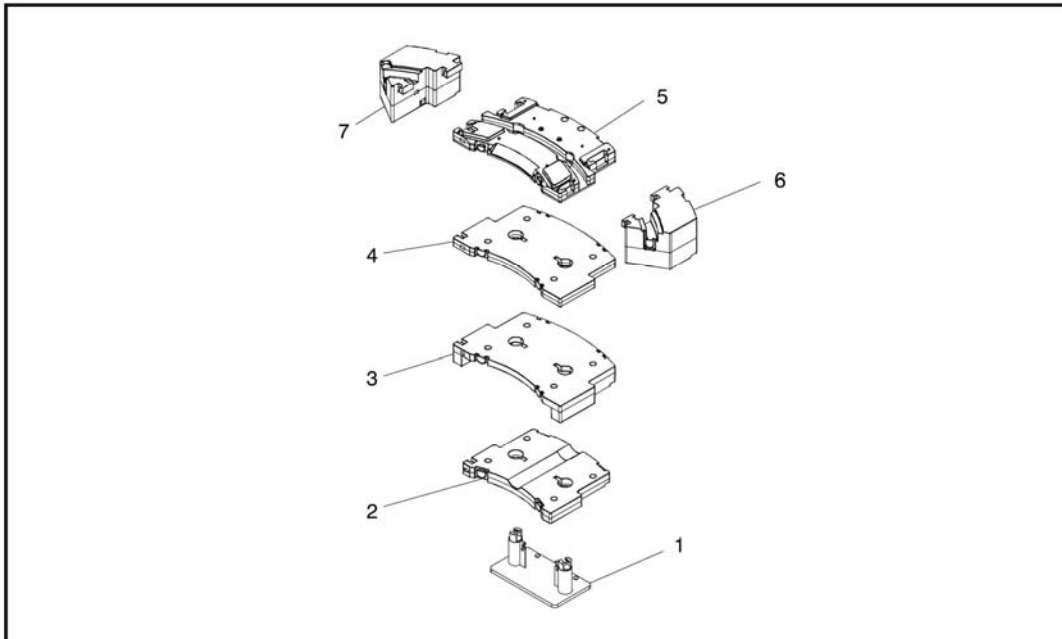

Counterweight Modules		1	2	3	4	5	6	7
		4,409 lb (2 000kg) tray	22,046 lb (10 000kg) piece	25,353 lb (11 500kg) piece	25,353 lb (11 500kg) piece	26,455 lb (12 000kg) top	26,455 lb (12 000kg) piece	26,455 lb (12 000kg) piece
Counterweight Usage Configurations	Standard	0 lb (0kg)						
		26,455 lb (12 000kg)	X	X				
		51,808 lb (23 500kg)	X	X	X			
		77,161 lb (35 000kg)	X	X	X	X		
		103,616 lb (47 000kg)	X	X	X	X	X	
		156,527 lb (71 000kg)	X	X	X	X	X	X

Carrier

General

- 9 ft 10 in (3.0m) wide with 20.5R25 tires
- 27 ft 10 in (8.5m) wheelbase (centerline of first axle to centerline of fifth axle)
- **Frame** – Box-type, torsion resistant, welded construction made of high tensile steel. Equipped with front and rear towing and tie-down lugs, tow connections, and access ladders.

Outriggers

Boxes – Two double box, front and rear welded to the carrier frame

Beams and Jacks – Four dual stage beams with Confined Area Lifting Capacities (CALC) provide selectable outrigger extensions of full and intermediate positions. Jacks with integral check valves, hydraulically controlled from the operator's cab and on both sides of carrier. Automatic leveling.

Pontoons – Four lightweight, stow'n go, 23.6" (60.0cm) square nylon pontoons with a contact area of 558 in² (3 600.0cm²) can be stored for road travel under the outrigger boxes.

Main Jack Reaction –277,000 lb (1 232.2kN) force and 496 psi (3 419.8kPa) ground bearing pressure

Steering and Axles

- ZF–Servocom dual circuit system provides hydraulic assisted steering with a mechanical link between the steering wheel and two front axles. The two rear axles steer hydraulically and operation is based on primary and auxiliary steering modes.

Primary Steering Mode – Axles 4 and 5 will automatically steer in combination with axles 1 and 2 based on travel speed:

Speed	Primary		
	Less than 15.5 mph (25km/h)	15.5–31.0 mph (25–50km/h)	Greater than 31.0 mph (50km/h)
Axle 1	Steered	Steered	Steered
Axle 2	Steered	Steered	Steered
Axle 3	Fixed (Lifted or Down)	Fixed (Lifted or Down)	Fixed (Lifted or Down)
Axle 4	Steered	Locked	Locked
Axle 5	Steered	Steered	Locked

Auxiliary Steering Modes – Five independent modes consisting of:

- **Independent Front:** Axles 1 and 2 (Axle 3 is lifted)
- **Combination:** Axles 1, 2, 4, and 5 (Axle 3 is lifted)
- **Crab:** Axles 1, 2, 4, and 5 (Axle 3 is lifted)
- **Independent Rear:** Axles 4 and 5 (Axle 3 is lifted)
- **Drive Away From Walls:** Temporary crab mode (Axle 3 is lifted)

The front, combination, and crab steering modes are controlled from the steering wheel and are selected by controls in the driver's cab. Momentary switches located in the driver's cab control the rear steering mode. Limited to 3rd gear travel.

- **Emergency Steering** – A pump is flange-mounted to the transfer box that provides hydraulic pressure to the steering circuit as long as the crane is in motion above 1.85 mph (3km/h).
- **Drive** – Two modes: 10 x 6 for highway travel: 1st, 4th, and 5th axles are driven. 10 x 8 for job-site travel: 1st, 2nd, 4th, and 5th axle are driven.
- **Axle 1** – Steered, driven for job-site travel
- **Axle 2** – Steered, driven
- **Axle 3** – Non steered, non driven, lift system
- **Axle 4** – Steered, driven
- **Axle 5** – Steered, driven
- **Inter-Axle Differential Lock** – Traction adding device that locks axles 1 and 2 with axles 4 and 5. Operated by a switch from the carrier cab.
- **Transverse (Cross-Axle) Differential Locks** – Traction adding device that locks differentials within axles 1, 2, 4, and 5. Operated by a switch from the carrier cab with a 10 second timer.

Suspension

Hydro-pneumatic, lockable with level adjustment and automatic ride height leveling. All axles have longitudinal and transverse trailing arms with leveling adjustment and locked cylinders. The carrier can be tilted laterally and longitudinally by controls in the carrier cab that adjust each individual suspension cylinder.

- Cylinder stroke: –4.6 in (118mm) / +6.2 in (158mm)

Third Axle Lift System – Axle 3 lifts independently for highway travel and job-site travel applications. Operated by a switch from the carrier cab.

Third Axle Boost – Axle 3 is presettable to a specific loading when the boom is over the front. Boost range is between 17,700 lb (8 028.6kg) and 30,800 lb (13 970.6kg).

■ Ground Control Outrigger/Suspension Controls

Environmentally sealed and ergonomically positioned, control stations located on the left and right side of the carrier with controls and indicators for crane operations including:

- Starts and stops carrier engine
- Throttles carrier engine up and down
- Suspension operation including:
 - Raise and lower suspension on outriggers
 - Automatic ride height leveling on tires
- Outrigger operation including:
 - Extends and retracts two beams together
 - Extends and retracts all jacks together
 - Automatic leveling on outriggers
- Outrigger lighting
- Monitor's contrast and brightness
- Electronic bubble level
- Levelness or inclination
- One position swing lock engagement indicator
- Outrigger force readout - optional

■ Tires and Wheels

Standard - Ten (single) 20.5R25 tires on steel disc wheels.

Optional - Ten (single) 16.00R25 tires on steel disc wheels.

- Tire inflation kit
- Spare tires and wheels - optional

■ Brakes

Service - Full air brakes on all wheel ends. Dual circuit compressed air system with air dryer.

Parking/Emergency - Spring loaded type, acting on 2nd, 4th, and 5th axles

Intarder - Hydrodynamic driveline brake that is integral to the transmission. Operated by a switch from the carrier cab.

■ Central Lubrication System

Automated lubrication unit that injects grease into the steering gear arms, steering knuckles, and suspension cylinders. Operated by a switch from the carrier's cab.

■ Electrical

Two batteries provide 24-volt operation and starting. CAN bus wiring and components, and integral self-test CSS (Control & Service System).

Lights

- Front lighting includes two main headlights, two high beam lights, two fog lights, two directional indicators, and two parking lights
- Rear lighting includes two rear combination panels each with directional indicator, parking light, brake light, fog light, reversing light, and license plate light
- Other equipment includes hazard/warning system, cab light, instrument panel light, signal horn, and two amber rotating beacons on cab roof
- Four lights to illuminate the outriggers

■ Engine

Specification	Mercedes Benz OM 502 LA
Numbers of cylinders	8
Cycle	4
Bore and Stroke: inch (mm)	5.12 x 5.91 (130x150)
Piston Displacement: in ³ (cm ³)	972.04 (15 929)
Max. Brake Horsepower: hp (kW)	530 (390) @ 1,800 rpm
Peak Torque: ft lb (Nm)	1,770 (2 400) @ 1,200 rpm
Alternator: volts - amps	24 - 100
Crankcase Capacity: qt (L)	42.27 (40)
	<ul style="list-style-type: none"> • Cruise control • Engine exhaust brake • Engine compression brake • Two thermostatically controlled, hydraulically driven radiator fans

■ Transmission

Automated - ZF AS-TRONIC (no clutch pedal) automated manual transmission with 16 forward gears and 2 reverse gears

Auxiliary - Transfer case with high/low range

■ Fuel Tank

One 140 gal (530L) capacity tank

■ Hydraulic System

Main Pumps

- One variable displacement piston pump for the front steering circuit 1, cooling fans, suspension, and outriggers
- One fixed displacement piston pump for front steering circuit 2
- Two fixed displacement gear pumps for rear steering
- One fixed displacement piston pump for emergency steering
- The carrier engine powers the pumps. Combined pump capacity of 65.6 gpm (248Lpm).

Hydraulic Reservoir - 76.6 gal (290L) capacity equipped with sight level gauge. Diffusers built in for deaeration.

Filtration - Two 12 micron, full flow, line filter in the control circuit. All oil is filtered prior to return to sump tank. Accessible for easy filter replacement.

■ Cab and Controls

Cab – Fully enclosed, two person full width cab of composite structure with acoustical insulation. Equipped with:

- Tinted and tempered glass windows
- Windshield wiper and washer
- Slide side windows of hardened glass
- Six way adjustable and air suspended driver and passenger seats with integrated three point safety belts and headrests
- Two heated and electrically adjustable rear–view mirrors
- One heated wide angle mirror and additional turn mirror
- Engine dependent warm–water heater with defroster nozzles for windshield and cab floor
- AM/FM radio with single disc CD player
- Adjustable sun visor
- Dome light
- 12 volt and 24 volt connection
- Air conditioning
- Fire extinguisher

Cab Instrumentation – Ergonomically positioned analog instrumentation for driving including:

- Speedometer with odometer
- Transmission mode, gear indication, and travel direction
- Engine coolant temperature
- Fuel level
- Tachometer with hourmeter

Dash Mounted – Controls and indicators for:

- Battery main shutoff
- Carrier throttle (0 to 1,200 rpm)
- Carrier lighting
- Auxiliary transmission high/low range
- 10x8 drive, inter–axle lock, and transverse differential lock
- Suspension operation, automatic leveling, and lock
- Cruise and intarder activation
- Mirror heating
- Warning lamps
- Engine/gearbox malfunction with audible alarm
- Service and park brake indication
- Steering system malfunction with audible alarm

Cockpit Multi–Vision (CMV) Display – Ergonomically positioned on the driver’s dash panel, digital instrumentation and indicators for crane operations including:

- Front and rear air pressure
- Air cleaner and hydraulic oil filter replacement
- Low engine oil and coolant
- Steering system malfunction
- Emergency steering activation
- CAN–BUS diagnostics
- Sensor fault
- Low voltage
- Tachometer fault
- Low fuel
- Suspension lifted and locked
- Auxiliary transmission high/low range
- Suspension leveled
- High beam headlights

- Third axle lifted
- Rear fog light activation
- 10x8 drive, inter–axle lock, and transverse differential lock
- One position swing lock engagement
- Intarder activation
- Axle oscillation activation
- Central lubrication activation
- Boom raised out of the boom rest
- Display contrast and brightness readout
- Crane service diagnostics readouts
- Electronic bubble level
- Axle loadings readouts
- Steering modes

Center Console – Controls and indicators for:

- Heating and air conditioning controls
- Transmission gear shifting
- Auxiliary steering controls
- Rear axle locking switch
- Mirror adjustments
- Park brake

Steering Column – Controls for:

- Carrier ignition
- Warning horn
- Turn indicators
- High beam headlights
- Steer wheel adjustments
- Cruise and intarder controls
- Windshield wipers and washers

Foot Controls – Controls for:

- Carrier service brakes
- Engine throttle

■ Additional Equipment

Standard:

- Pneumatic and electrical quick disconnect connectors mounted on the rear bumper for boom dolly brakes and lights
- Emergency function overrides
- Aluminum full deck fenders and ladders
- Hook block and ball bumper tie backs
- Left and right side carrier storage boxes
- Hook ball storage
- Folding ladder (stowed under the carrier cab)
- Handling slings
- Mud flaps
- Tool box with tools
- Grease gun
- First aid kit
- Tire inflation system
- Battery jumper cables

Carrier Speeds and Gradeability

ZF Astronic		Speed				Gradeability (@ Peak Torque Except Creep @ Idle)	
		High Range (0.800)		Low Range (1.836)		High Range (0.800)	Low Range (1.836)
Gear	Ratio	mph	km/h	mph	km/h	% Grade	
16th	0.83	52.8	85.0	26.1	42.0	1	2
15th	1.00	49.7	80.0	21.7	35.0	2	3
14th	1.18	42.3	68.0	18.6	30.0	3	3
13th	1.43	34.8	56.0	14.9	24.0	3	4
12th	1.73	28.6	46.0	12.4	20.0	4	5
11th	2.09	23.6	38.0	10.6	17.0	6	7
10th	2.56	19.3	31.0	8.7	14.0	7	8
9th	3.09	16.2	26.0	6.8	11.0	9	11
8th	3.78	13.0	21.0	5.6	9.0	11	13
7th	4.57	11.2	18.0	5.0	8.0	14	16
6th	5.39	9.3	15.0	4.3	7.0	16	19
5th	6.52	7.5	12.0	3.1	5.0	20	24
4th	7.89	6.2	10.0	2.5	4.0	25	30
3rd	9.54	5.0	8.0	2.5	4.0	31	37
2nd	11.68	4.3	7.0	1.9	3.0	39	47
1st	14.12	3.7	6.0	1.9	3.0	47	61
Reverse 1 (Low)	13.07	3.7	6.0	1.9	3.0	45	55
Reverse 2 (High)	10.81	4.3	7.0	1.9	3.0	36	43
1st @ 800 rpm	14.12	1.4	2.0	0.6	1.0	N/A	N/A
Reverse 1 (Low) @ 800 rpm	13.07	1.4	2.0	0.6	1.0	N/A	N/A
Reverse 2 (High) @ 800 rpm	10.81	1.4	2.0	0.6	1.0	N/A	N/A

Based on a 132,277.4 lb (60 000kg) gross vehicle weight with 16.00R25 and 20.5R25 tires

Axle Loads – English

Base crane with full tank of fuel and no counterweight	Gross Vehicle Weight ⁽¹⁾	Axle 1	Axle 2	Axle 3*	Axle 4	Axle 5
	lb	lb	lb	lb	lb	lb
	136,339	26,549	26,737	26,500	28,357	28,196
Third axle lifted	---	6,930	6,930	-26,500	6,320	6,320
Driver in carrier cab	250	172	172	0	-47	-47
16.00R25 tires (instead of standard)	-1,036	-329	-329	0	-189	-189
Auxiliary winch with 1,148 ft of 0.83 in diameter rope	3,647	-1,068	-1,068	0	2,892	2,892
[6&7] counterweight 26,455 lb each on upper	52,910	-12,365	-12,365	0	38,820	38,820
[5] counterweight 26,455 lb on upper – requires ctwt [1–4]	26,455	-6,183	-6,183	0	19,410	19,410
[4] counterweight 25,353 lb on upper – requires ctwt [1–3]	25,353	-5,925	-5,925	0	18,602	18,602
[3] counterweight 25,353 lb on upper – requires ctwt [1&2]	25,353	-5,877	-5,877	0	18,553	18,553
[2] counterweight 22,046 lb on upper – requires ctwt [1]	22,046	-5,145	-5,145	0	16,168	16,168
[1] counterweight 4,409 lb on upper	4,409	-1,029	-1,029	0	3,234	3,234
17.7–43.3 ft offsettable, two piece lattice fly (stowed)	3,376	1,812	1,812	0	-124	-124
Auxiliary lifting sheave (erected)	205	186	186	0	-83	-83
88.2 ton 5 sheave quick–reeve hook block with safety latch (stowed at front bumper)	2,536	2,209	2,209	0	-941	-941
88.2 ton 5 sheave quick–reeve hook block with safety latch (stowed at boom head)	2,536	2,312	2,312	0	-1,044	-1,044
27.6 ton 1 sheave quick–reeve hook block with safety latch (stowed at front bumper)	992	864	864	0	-368	-368
27.6 ton 1 sheave quick–reeve hook block with safety latch (stowed at boom head)	992	904	904	0	-408	-408
11.0 ton swivel hook ball with safety latch (stowed in carrier storage)	662	-109	-109	0	440	440
11.0 ton swivel hook ball with safety latch (stowed at boom head)	662	603	603	0	-272	-272

Counterweight Load Transfer	Axle 1	Axle 2	Axle 3*	Axle 4	Axle 5
	lb	lb	lb	lb	lb
Transfer [5] counterweight 26,455 lb to carrier deck	9,758	9,758	0	3,470	3,470
Transfer [4] counterweight 25,353 lb to carrier deck	9,351	9,351	0	3,325	3,325
Transfer [3] counterweight 25,353 lb to carrier deck	9,303	9,303	0	3,374	3,374
Transfer [2] counterweight 22,046 lb to carrier deck	8,124	8,124	0	2,899	2,899
Transfer [1] counterweight 4,409 lb to carrier deck	1,625	1,625	0	580	580

(¹) Adjust gross vehicle weight and axle loading according to component weight. All weights are $\pm 3\%$.

*Axle 3 is presettable to a specific loading when boom is over the front. Boost range is between 17,700 lb to 30,800 lb.

Tire	Maximum Axle Load @ 50 mph Average Speed
20.5R25	26,015 lb
16.00R25	24,471 lb

Axle Loads – Metric

Base crane with full tank of fuel and no counterweight	Gross Vehicle Weight ⁽¹⁾	Axle 1	Axle 2	Axle 3*	Axle 4	Axle 5
	kg	kg	kg	kg	kg	kg
	61 842	12 042	12 128	12 020	12 863	12 790
Third axle lifted	---	3 144	3 144	-12 020	2 867	2 867
Driver in carrier cab	113	78	78	0	-21	-21
16.00R25 tires (instead of standard)	-470	-149	-149	0	-86	-86
Auxiliary winch with 350m of 22mm diameter rope	1 654	-485	-485	0	1 312	1 312
[6&7] counterweight 12 000kg each on upper	24 000	-5 609	-5 609	0	17 609	17 609
[5] counterweight 12 000kg on upper – requires ctwt [1-4]	12 000	-2 804	-2 804	0	8 804	8 804
[4] counterweight 11 500kg on upper – requires ctwt [1-3]	11 500	-2 688	-2 688	0	8 438	8 438
[3] counterweight 11 500kg on upper – requires ctwt [1&2]	11 500	-2 666	-2 666	0	8 416	8 416
[2] counterweight 10 000kg on upper – requires ctwt [1]	10 000	-2 334	-2 334	0	7 334	7 334
[1] counterweight 2 000kg on upper	2 000	-467	-467	0	1 467	1 467
5.4-13.2m offsettable, two piece lattice fly (stowed)	1 531	822	822	0	-56	-56
Auxiliary lifting sheave (erected)	93	84	84	0	-38	-38
80 mt 5 sheave quick-reeve hook block with safety latch (stowed at front bumper)	1 150	1 002	1 002	0	-427	-427
80 mt 5 sheave quick-reeve hook block with safety latch (stowed at boom head)	1 150	1 049	1 049	0	-474	-474
25 mt 1 sheave quick-reeve hook block with safety latch (stowed at front bumper)	450	392	392	0	-167	-167
25 mt 1 sheave quick-reeve hook block with safety latch (stowed at boom head)	450	410	410	0	-185	-185
10 mt swivel hook ball with safety latch (stowed in carrier storage)	300	-49	-49	0	200	200
10 mt swivel hook ball with safety latch (stowed at boom head)	300	274	274	0	-123	-123

Counterweight Load Transfer	Axle 1	Axle 2	Axle 3*	Axle 4	Axle 5
	kg	kg	kg	kg	kg
Transfer [5] counterweight 12 000kg to carrier deck	4 426	4 426	0	1 574	1 574
Transfer [4] counterweight 11 500kg to carrier deck	4 242	4 242	0	1 508	1 508
Transfer [3] counterweight 11 500kg to carrier deck	4 220	4 220	0	1 530	1 530
Transfer [2] counterweight 10 000kg to carrier deck	3 685	3 685	0	1 315	1 315
Transfer [1] counterweight 2 000kg to carrier deck	737	737	0	263	263

⁽¹⁾ Adjust gross vehicle weight and axle loading according to component weight. All weights are $\pm 3\%$.

*Axle 3 is presettable to a specific loading when boom is over the front. Boost range is between 8 028.6kg to 13 970.6kg.

Tire	Maximum Axle Load @ 80km/h Average Speed
20.5R25	11 800kg
16.00R25	11 100kg

Axle Loads with 2–Axle or 3–Axle Boom Dolly (3rd Axle Down) – English

Base crane with full tank of fuel and no counterweight	Gross Vehicle Weight ⁽¹⁾	Axle 1	Axle 2	Axle 3	Axle 4	Axle 5	Dolly
	lb	lb	lb	lb	lb	lb	lb
	136,339	18,426	18,614	20,772	20,927	20,766	36,834
Driver in carrier cab	250	182	182	-38	-38	-38	0
16.00R25 tires (instead of standard)	-1,036	-290	-290	-152	-152	-152	0
Auxiliary winch with 1,148 ft of 0.83 in diameter rope	3,647	1,506	1,506	212	212	212	0
[6&7] counterweight 26,455 lb each on upper	52,910	18,050	18,050	5,603	5,603	5,603	0
[5] counterweight 26,455 lb on upper – requires ctwt [1–4]	26,455	9,025	9,025	2,802	2,802	2,802	0
[4] counterweight 25,353 lb on upper– requires ctwt [1–3]	25,353	8,649	8,649	2,685	2,685	2,685	0
[3] counterweight 25,353 lb on upper – requires ctwt [1&2]	25,353	8,590	8,590	2,724	2,724	2,724	0
[2] counterweight 22,046 lb on upper – requires ctwt [1]	22,046	-5,145	-5,145	0	16,168	16,168	0
[1] counterweight 4,409 lb on upper	4,409	1,502	1,502	468	468	468	0
17.7–43.3 ft offsettable, two piece lattice fly (stowed)	3,376	168	168	135	135	135	2,633
Auxiliary lifting sheave (erected)	205	-10	-10	-8	-8	-8	247
88.2 ton 5 sheave quick–reeve hook block with safety latch (stowed at boom head)	2,536	-62	-62	-50	-50	-50	2,809
88.2 ton 5 sheave quick–reeve hook block with safety latch (stowed on dolly)	2,536	0	0	0	0	0	2,536
27.6 ton 1 sheave quick–reeve hook block with safety latch (stowed at boom head)	992	-24	-24	-19	-19	-19	1,099
27.6 ton 1 sheave quick–reeve hook block with safety latch (stowed on dolly)	992	0	0	0	0	0	992
11.0 ton swivel hook ball with safety latch (stowed in carrier storage)	662	-202	-202	355	355	355	0
11.0 ton swivel hook ball with safety latch (stowed at boom head)	662	-16	-16	-13	-13	-13	733
11.0 ton swivel hook ball with safety latch (stowed on dolly)	662	0	0	0	0	0	662
2–axle boom dolly	5,500	0	0	0	0	0	5,500
3–axle boom dolly	8,800	0	0	0	0	0	8,800
3–axle boom dolly (12 ft 6.5 in wheelbase)	8,800	0	0	0	0	0	8,800
3–axle boom dolly (23 ft 7 in wheelbase)	10,500	0	0	0	0	0	10,500

(¹) Adjust gross vehicle weight and axle loading according to component weight. All weights are ±3%.

Tire	Maximum Axle Load @ 50 mph Average Speed
20.5R25	26,015 lb
16.00R25	24,471 lb

Axle Loads with 2-Axle or 3-Axle Boom Dolly (3rd Axle Down) – Metric

Base crane with full tank of fuel and no counterweight	Gross Vehicle Weight ⁽¹⁾	Axle 1	Axle 2	Axle 3*	Axle 4	Axle 5	Dolly
	kg	kg	kg	kg	kg	kg	kg
	61 842	9 302	9 387	10 181	10 252	10 179	12 541
Driver in carrier cab	113	82	82	-17	-17	-17	0
16.00R25 tires (instead of standard)	-470	-131	-131	-69	-69	-69	0
Auxiliary winch with 350m of 22mm diameter rope	1 654	683	683	96	96	96	0
[6&7] counterweight 12 000kg each on upper	24 000	8 187	8 187	2 542	2 542	2 542	0
[5] counterweight 12 000kg on upper – requires ctwt [1-4]	12 000	4 094	4 094	1 271	1 271	1 271	0
[4] counterweight 11 500kg on upper – requires ctwt [1-3]	11 500	3 923	3 923	1 218	1 218	1 218	0
[3] counterweight 11 500kg on upper – requires ctwt [1-2]	11 500	3 896	3 896	1 236	1 236	1 236	0
[2] counterweight 10 000kg on upper – requires ctwt [1]	10 000	-2 334	-2 334	7 334	7 334	7 334	0
[1] counterweight 2 000kg on upper	2 000	681	681	212	212	212	0
5.4-13.2m offsettable, two piece lattice fly (stowed)	1 531	76	76	61	61	61	1 194
Auxiliary lifting sheave (erected)	93	-4	-4	-3	-3	-3	112
80 mt 5 sheave quick-reeve hook block with safety latch (stowed at boom head)	1 150	-28	-28	-23	-23	-23	1 274
80 mt 5 sheave quick-reeve hook block with safety latch (stowed on dolly)	1 150	0	0	0	0	0	1 150
25 mt 1 sheave quick-reeve hook block with safety latch (stowed at boom head)	450	-11	-11	-9	-9	-9	498
25 mt 1 sheave quick-reeve hook block with safety latch (stowed on dolly)	450	0	0	0	0	0	450
10 mt swivel hook ball with safety latch (stowed in carrier storage)	300	-91	-91	161	161	161	0
10 mt swivel hook ball with safety latch (stowed at boom head)	300	-7	-7	-6	-6	-6	333
10 mt swivel hook ball with safety latch (stowed on dolly)	300	0	0	0	0	0	300
2-axle boom dolly	2 495	0	0	0	0	0	2 495
3-axle boom dolly	3 992	0	0	0	0	0	3 992
3-axle boom dolly (3.82m wheelbase)	3 992	0	0	0	0	0	3 992
3-axle boom dolly (7.19m wheelbase)	4 763	0	0	0	0	0	4 763

⁽¹⁾ Adjust gross vehicle weight and axle loading according to component weight. All weights are ±3%.

Tire	Maximum Axle Load @ 80km/h Average Speed
20.5R25	11 800kg
16.00R25	11 100kg

Axle Loads with 2-Axle or 3-Axle Boom Dolly (3rd Axle Lifted) – English

Base crane with full tank of fuel and no counterweight	Gross Vehicle Weight ⁽¹⁾	Axle 1	Axle 2	Axle 3	Axle 4	Axle 5	Dolly
	lb	lb	lb	lb	lb	lb	lb
	136,339	26,378	26,566	0	27,954	27,793	27,649
Driver in carrier cab	250	172	172	0	-47	-47	0
16.00R25 tires (instead of standard)	-1,036	-329	-329	0	-189	-189	0
Auxiliary winch with 1,148 ft of 0.83 in diameter rope	3,647	1,561	1,561	0	262	262	0
[6&7] counterweight 26,455 lb each on upper	52,910	19,515	19,515	0	6,940	6,940	0
[5] counterweight 26,455 lb on upper – requires ctwt [1-4]	26,455	9,758	9,758	0	3,470	3,470	0
[4] counterweight 25,353 lb on upper – requires ctwt [1-3]	25,353	9,351	9,351	0	3,325	3,325	0
[3] counterweight 25,353 lb on upper – requires ctwt [1&2]	25,353	9,303	9,303	0	3,374	3,374	0
[2] counterweight 22,046 lb on upper – requires ctwt [1]	22,046	-5,145	-5,145	0	16,168	16,168	0
[1] counterweight 4,409 lb on upper	4,409	1,625	1,625	0	580	580	0
17.7-43.3 ft offsettable, two piece lattice fly (stowed)	3,376	204	204	0	168	168	2,633
Auxiliary lifting sheave (erected)	205	-12	-12	0	-9	-9	247
88.2 ton 5 sheave quick-reeve hook block with safety latch (stowed at boom head)	2,536	-75	-75	0	-62	-62	2,809
88.2 ton 5 sheave quick-reeve hook block with safety latch (stowed on dolly)	2,536	0	0	0	0	0	3,536
27.6 ton 1 sheave quick-reeve hook block with safety latch (stowed at boom head)	992	-29	-29	0	-24	-24	1,099
27.6 ton 1 sheave quick-reeve hook block with safety latch (stowed on dolly)	992	0	0	0	0	0	992
11.0 ton swivel hook ball with safety latch (stowed in carrier storage)	662	-109	-109	0	440	440	0
11.0 ton swivel hook ball with safety latch (stowed at boom head)	662	-20	-20	0	-16	-16	733
11.0 ton swivel hook ball with safety latch (stowed on dolly)	662	0	0	0	0	0	662
2-axle boom dolly	5,500	0	0	0	0	0	5,500
3-axle boom dolly	8,800	0	0	0	0	0	8,800
3-axle boom dolly (12 ft 6.5 in wheelbase)	8,800	0	0	0	0	0	8,800
3-axle boom dolly (23 ft 7 in wheelbase)	10,500	0	0	0	0	0	10,500

(¹) Adjust gross vehicle weight and axle loading according to component weight. All weights are ±3%.

Tire	Maximum Axle Load @ 50 mph Average Speed
20.5R25	26,015 lb
16.00R25	24,471 lb

Axle Loads with 2-Axle or 3-Axle Boom Dolly (3rd Axle Lifted) – Metric

Base crane with full tank of fuel and no counterweight	Gross Vehicle Weight ⁽¹⁾	Axle 1	Axle 2	Axle 3*	Axle 4	Axle 5	Dolly
	kg	kg	kg	kg	kg	kg	kg
	61 842	11 965	12 050	0	12 680	12 607	12 541
Driver in carrier cab	113	78	78	0	-21	-21	0
16.00R25 tires (instead of standard)	-470	-149	-149	0	-86	-86	0
Auxiliary winch with 350m of 22mm diameter rope	1 654	708	708	0	119	119	0
[6&7] counterweight 12 000kg each on upper	24 000	8 852	8 852	0	3 148	3 148	0
[5] counterweight 12 000kg on upper – requires ctwt [1-4]	12 000	4 426	4 426	0	1 574	1 574	0
[4] counterweight 11 500kg on upper – requires ctwt [1-3]	11 500	4 242	4 242	0	1 508	1 508	0
[3] counterweight 11 500kg on upper – requires ctwt [1&2]	11 500	4 220	4 220	0	1 530	1 530	0
[2] counterweight 10 000kg on upper – requires ctwt [1]	10 000	-2 334	-2 334	0	7 334	7 334	0
[1] counterweight 2 000kg on upper	2 000	737	737	0	263	263	0
5.4-13.2m offsettable, two piece lattice fly (stowed)	1 531	92	92	0	76	76	1 194
Auxiliary lifting sheave (erected)	93	-5	-5	0	-4	-4	112
80 mt 5 sheave quick-reeve hook block with safety latch (stowed at boom head)	1 150	-34	-34	0	-28	-28	1 274
80 mt 5 sheave quick-reeve hook block with safety latch (stowed on dolly)	1 150	0	0	0	0	0	1 150
25 mt 1 sheave quick-reeve hook block with safety latch (stowed at boom head)	450	-13	-13	0	-11	-11	498
25 mt 1 sheave quick-reeve hook block with safety latch (stowed on dolly)	450	0	0	0	0	0	450
10 mt swivel hook ball with safety latch (stowed in carrier storage)	300	-49	-49	0	199	199	0
10 mt swivel hook ball with safety latch (stowed at boom head)	300	-9	-9	0	-7	-7	333
10 mt swivel hook ball with safety latch (stowed on dolly)	300	0	0	0	0	0	300
2-axle boom dolly	2 495	0	0	0	0	0	2 495
3-axle boom dolly	3 992	0	0	0	0	0	3 992
3-axle boom dolly (3.82m wheelbase)	3 992	0	0	0	0	0	3 992
3-axle boom dolly (7.19m wheelbase)	4 763	0	0	0	0	0	4 763

⁽¹⁾ Adjust gross vehicle weight and axle loading according to component weight. All weights are ±3%.

Tire	Maximum Axle Load @ 80km/h Average Speed
20.5R25	11 800kg
16.00R25	11 100kg

General Dimensions

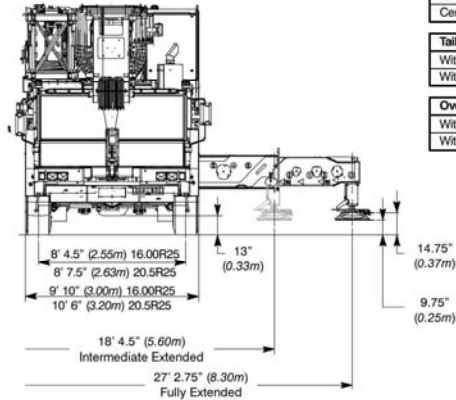
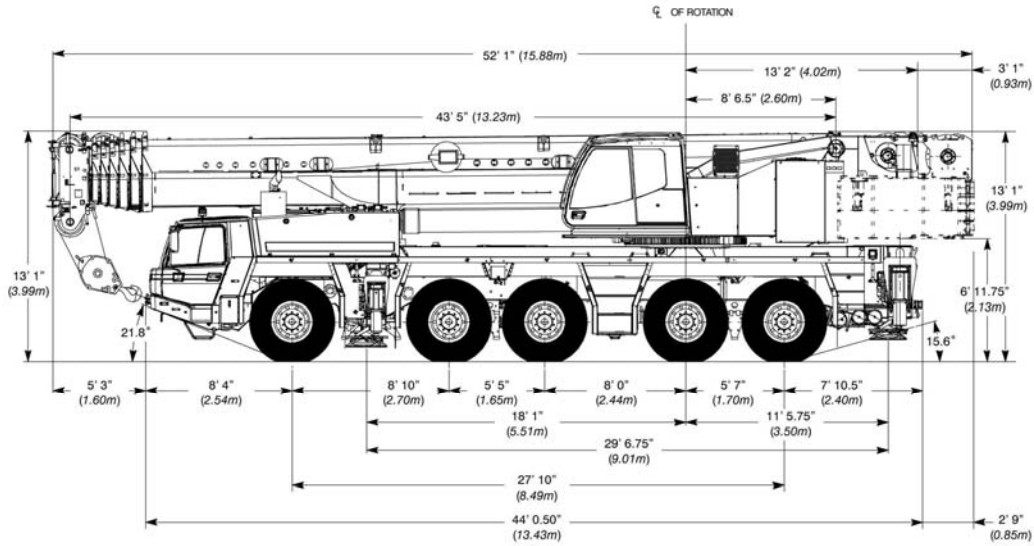

Turning Radius	20.5R25		16.00R25	
	English	Metric	English	Metric
Wall to wall over carrier	36' 0"	11.0m	35' 9"	10.9m
Wall to wall over boom	38' 4"	11.7m	38' 1"	11.6m
Wall to wall over boom attachment	40' 7"	12.4m	40' 4"	12.3m
Curb to curb	32' 2"	9.80m	31' 11"	9.72m
Centerline of tire	31' 5"	9.6m	31' 2"	9.5m

Tail Swing	English	Metric
With auxiliary winch	16' 8"	5.1m
Without auxiliary winch	14' 5"	4.4m

Overall Width	English	Metric
With 51,808-103,616 lb (23,500-37,000kg) counterweight	15' 1"	4.6m
With 156,527 lb (71,000kg) counterweight	18' 5"	5.6m

Not To Scale

5519 (supersedes 5485) - 0206 - R4

17

Working Range Diagram

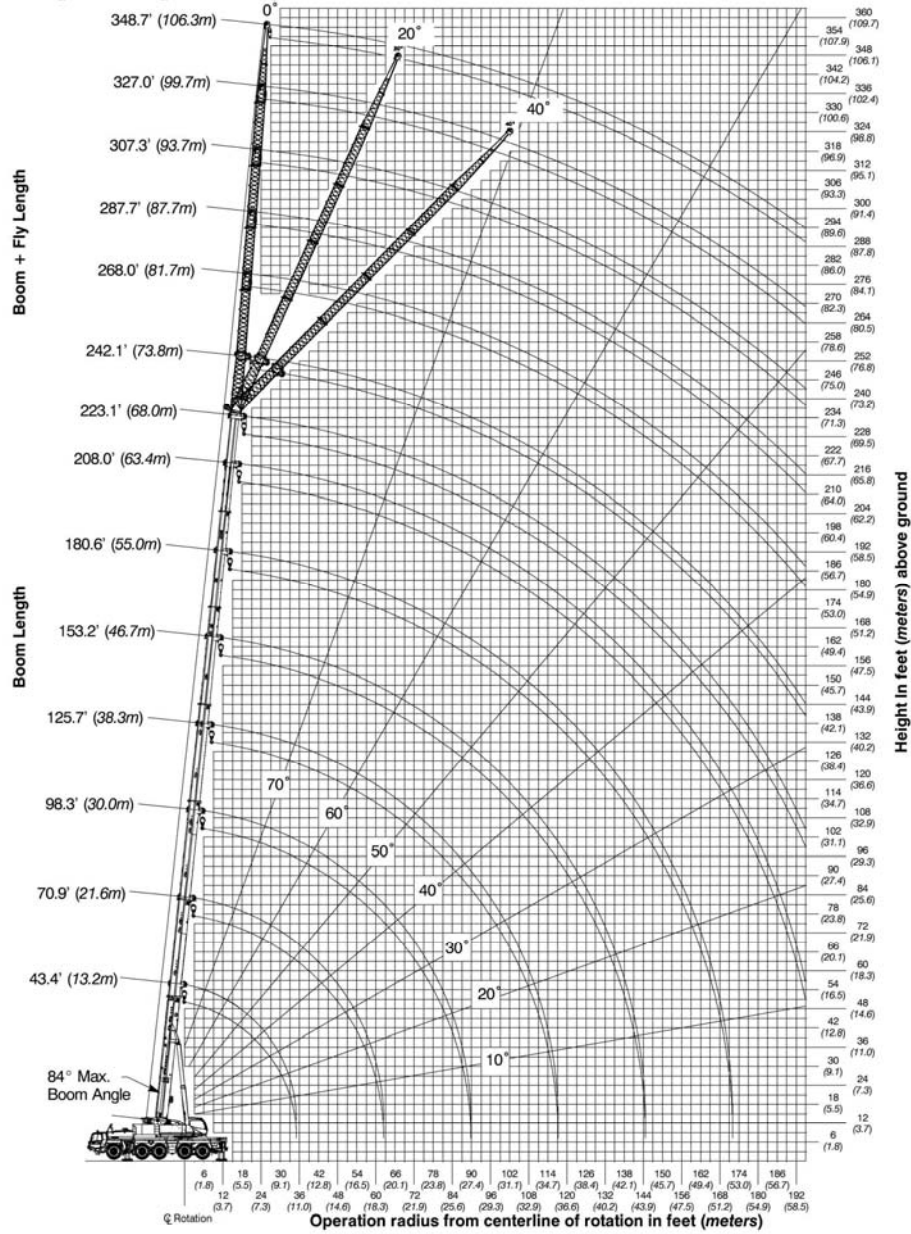

Link-Belt Cranes

ATC-3250

Boom Extend Modes

Boom Length		Sections Length					
ft	m	Tele I	Tele II	Tele III	Tele IV	Tele V	Tele VI
43.3	13.2	0	0	0	0	0	0
57.1	17.4	0	46	0	0	0	0
		0	0	0	0	0	46
70.9	21.6	46	46	0	0	0	0
		0	0	0	0	46	46
		0	0	0	0	0	92
84.6	25.8	92	46	0	0	0	0
		46	46	46	0	0	0
		0	0	0	46	46	46
		0	0	0	0	46	92
98.4	30.0	92	46	46	0	0	0
		46	46	46	46	0	0
		0	0	46	46	46	46
		0	0	0	0	92	92
111.9	34.1	92	46	46	46	0	0
		46	46	46	46	46	0
		0	46	46	46	46	46
		0	0	0	46	92	92
125.7	38.3	92	46	46	46	46	0
		46	46	46	46	46	46
		0	0	0	46	46	46
139.4	42.5	92	92	46	46	46	0
		92	46	46	46	46	46
		46	46	46	46	46	92
		0	0	46	92	92	92
153.2	46.7	92	92	46	46	46	46
		46	46	46	46	92	92
		0	0	92	92	92	92
167.0	50.9	92	92	92	46	46	46
		92	46	46	46	92	92
		0	46	92	92	92	92
180.4	55.0	92	92	92	92	46	46
		46	92	92	92	92	46
		0	92	92	92	92	92
194.2	59.2	92	92	92	92	92	46
		46	92	92	92	92	92
208.0	63.4	92	92	92	92	92	92
223.1	68.0	100	100	100	100	100	100

Main Boom Lift Capacity Charts

156,527 lb Counterweight – Fully Extended Outriggers – 360° Rotation (All Capacities Are Listed In Thousand Pounds)																
Radius (ft)	Boom Length (ft)														Radius (ft)	
	43.3 (*)	43.3	57.1	70.9	84.6	98.4	111.9	125.7	139.4	153.2	167.0	180.4	194.2	208.0		223.1
8	500.0*															8
9	442.1*															9
10	394.6*	385.6*	308.6*	308.6*	251.3*											10
12	367.1*	346.1*	308.6*	308.6*	247.5*	199.5										12
14	341.5*	317.1*	305.7*	304.5*	233.3	199.5										14
16	306.9*	286.0*	284.9*	283.5*	227.1	193.7	154.3									16
18	274.1*	260.7*	260.1*	258.5*	227.1	184.1	154.3	120.2								18
20	244.6*	237.4	237.4	235.2	225.4	174.4	153.5	120.2	95.9							20
25	194.9	194.3	193.4	191.5	193.0	170.9	139.1	120.2	95.9	76.1						25
30	159.5	159.5	158.6	156.6	157.9	159.7	127.9	113.7	95.0	76.1	62.8	50.7				30
35			133.2	131.4	132.6	134.2	126.0	103.1	88.3	75.5	62.8	50.7	41.4			35
40			114.1	112.4	113.5	115.0	117.2	93.8	82.5	71.3	62.1	50.7	41.4	33.1	27.6	40
45			99.5	97.7	98.8	100.4	102.2	89.1	79.1	67.0	59.6	50.3	41.4	33.1	27.6	45
50				86.1	87.1	88.6	90.4	84.5	74.1	64.1	56.5	48.9	41.4	33.1	27.6	50
55				76.5	77.3	78.8	80.6	79.5	68.8	61.1	53.4	46.9	41.0	33.1	27.6	55
60				68.1	69.5	71.1	72.3	73.9	63.8	57.6	50.4	44.6	40.0	33.1	27.6	60
65					65.3	67.1	67.5	67.0	59.6	54.4	47.7	42.4	38.1	33.1	27.6	65
70					58.9	60.4	64.1	62.5	55.8	51.7	45.3	40.2	36.4	32.8	27.6	70
75						56.2	59.6	57.8	52.4	48.9	43.1	38.2	34.8	31.9	27.6	75
80						53.5	54.4	52.8	49.3	46.1	40.9	36.4	33.2	30.6	27.4	80
85						50.7	49.7	48.1	46.3	43.8	38.9	34.7	31.8	29.4	26.9	85
90							45.6	44.1	42.4	41.4	37.2	33.2	30.5	28.2	25.6	90
95							42.1	40.4	38.9	38.5	35.1	31.8	29.1	27.0	24.3	95
100							38.9	37.2	35.7	35.3	32.9	30.4	27.8	25.9	23.0	100
110								32.0	29.9	29.2	27.9	25.7	24.1	20.8	110	
120									29.1	25.5	25.9	25.0	23.7	22.2	18.9	120
130										23.5	23.4	22.2	21.1	20.7	17.2	130
140										20.3	21.2	19.2	18.9	18.4	15.7	140
150											18.7	17.1	16.7	16.7	14.2	150
160												15.8	15.3	15.3	13.1	160
170												14.4	14.0	13.8	12.0	170
180													12.9	12.1	10.9	180
190														10.4	9.5	190
200															8.6	200
210															7.7	210

* Special Conditions Or Wire Rope Required
(*) Over Rear Only With Swing Lock Engaged

This information is not for crane operation. Operator must refer to the in-cab information for crane operation. Rated lifting capacities shown on fully extended outriggers do not exceed 85% of the tipping loads.

103,616 lb Counterweight – Fully Extended Outriggers – 360° Rotation (All Capacities Are Listed In Thousand Pounds)																
Radius (ft)	Boom Length (ft)													Radius (ft)		
	43.3 (1)	43.3	57.1	70.9	84.6	98.4	111.9	125.7	139.4	153.2	167.0	180.4	194.2		208.0	223.1
10	394.6*	381.0*	308.6*	308.6*	251.3*											10
12	362.9*	336.0*	308.6*	308.6*	247.5*	199.5										12
14	319.5*	299.4*	296.9*	295.7*	233.3	199.5										14
16	278.8*	269.2*	269.2*	266.9*	227.1	193.7	154.3									16
18	248.6*	244.7*	244.7*	242.5*	225.5	184.1	154.3	120.2								18
20	221.6	221.6	221.5	219.4	220.5	174.4	153.5	120.2	95.9							20
25	174.7	174.7	173.8	172.0	173.3	167.3	139.1	120.2	95.9	76.1						25
30	142.1	142.1	141.2	139.4	95.9	142.3	127.9	113.7	95.0	76.1	62.8	50.7				30
35			118.4	116.5	88.9	119.3	120.1	103.1	88.3	75.5	62.8	50.7	41.4			35
40			100.8	97.8	81.6	101.4	102.1	93.5	82.5	71.3	62.1	50.7	41.4	33.1	27.6	40
45			86.8	80.0	74.9	83.8	86.3	86.4	79.1	67.0	59.6	50.3	41.4	33.1	27.6	45
50				69.7	69.3	74.9	76.4	75.3	71.6	64.1	56.5	48.9	41.4	33.1	27.6	50
55				61.0	64.4	68.4	66.4	64.7	62.9	59.9	53.4	46.9	41.0	33.1	27.6	55
60				57.1	60.0	62.0	57.8	56.0	54.3	53.8	50.3	44.6	40.0	33.1	27.6	60
65					55.3	55.1	50.9	49.1	47.5	46.9	46.9	42.4	38.1	33.1	27.6	65
70					50.0	49.4	45.3	43.6	44.2	41.4	43.9	40.2	36.4	32.8	27.6	70
75						44.5	41.3	39.4	40.3	37.2	40.1	37.9	34.8	31.9	27.6	75
80						40.3	38.3	36.3	36.4	34.1	35.9	35.5	33.0	30.6	27.4	80
85						36.6	35.4	34.5	33.9	32.3	32.7	33.0	31.0	29.4	26.9	85
90							32.4	30.8	31.8	30.9	30.7	29.8	29.0	28.2	25.6	90
95							29.7	28.1	29.5	29.3	28.6	28.0	27.0	26.6	24.3	95
100							27.2	25.5	27.0	27.4	26.4	26.3	25.3	24.8	22.9	100
110								21.3	22.7	23.7	22.0	22.5	22.3	21.4	20.3	110
120									19.8	20.1	19.9	20.1	19.3	18.2	17.8	120
130										17.8	17.9	17.5	16.4	15.1	15.1	130
140										16.5	16.0	15.0	14.0	12.6	12.6	140
150											14.0	12.8	11.8	10.4	10.4	150
160												11.0	9.9	8.6	8.5	160
170													9.6	8.3	6.9	170
180														7.0	5.7	180
190															4.4	190
200																200
210																210

* Special Conditions Or Wire Rope Required
(1) Over Rear Only With Swing Lock Engaged

This information is not for crane operation. Operator must refer to the in-cab information for crane operation. Rated lifting capacities shown on fully extended outriggers do not exceed 85% of the tipping loads.

77,161 lb Counterweight – Fully Extended Outriggers – 360° Rotation (All Capacities Are Listed In Thousand Pounds)																	
Radius (ft)	Boom Length (ft)												Radius (ft)				
	43.3 (1)	43.3	57.1	70.9	84.6	98.4	111.9	125.7	139.4	153.2	167.0	180.4		194.2	208.0	223.1	
10	394.0*	370.1*	308.6*	308.6*	251.3*											10	
12	352.8*	326.1*	307.3*	306.6*	247.5*	199.5										12	
14	303.0*	290.1*	289.5*	287.3*	233.3	199.5										14	
16	265.0*	260.3*	259.2*	257.0*	227.1	193.7	154.3									16	
18	235.8	234.2	233.2	231.1	219.4	184.1	154.3	120.2								18	
20	209.3	209.3	208.5	206.5	208.0	174.4	153.5	120.2	95.9							20	
25	164.1	164.1	163.3	161.4	162.7	158.0	139.1	120.2	95.9	76.1						25	
30	134.1	134.1	132.9	131.0	129.5	125.9	123.4	113.0	95.0	76.1	62.8	50.7				30	
35			110.8	107.9	107.1	102.6	101.2	95.9	88.3	75.5	62.8	50.7	41.4			35	
40			87.8	85.1	86.9	89.3	90.1	84.7	79.7	71.1	62.1	50.7	41.4	33.1	27.6	40	
45			72.1	69.9	74.9	75.5	79.0	73.0	68.6	65.2	59.6	50.3	41.4	33.1	27.6	45	
50				64.8	67.3	66.9	67.8	62.0	59.3	57.7	55.1	48.9	41.4	33.1	27.6	50	
55				58.7	59.4	58.8	58.1	52.8	52.1	50.2	49.7	46.7	41.0	33.1	27.6	55	
60				51.3	51.6	51.1	50.4	45.7	47.6	43.5	43.6	43.6	40.0	33.1	27.6	60	
65					45.7	45.1	44.2	41.5	43.9	38.6	39.3	38.5	38.1	33.1	27.6	65	
70					40.9	40.2	39.3	37.5	39.2	36.4	35.5	35.5	36.4	32.8	27.6	70	
75						36.0	35.2	33.5	35.0	33.9	31.6	32.7	33.5	31.0	27.6	75	
80						32.3	31.6	29.8	31.4	31.2	29.4	30.2	29.8	28.4	27.0	80	
85						29.5	28.4	26.6	28.2	28.8	27.9	27.7	27.7	26.6	25.0	85	
90							25.1	23.8	25.6	26.5	26.2	25.2	25.7	24.4	22.4	90	
95							24.2	22.5	24.3	24.7	24.5	23.4	23.4	22.2	20.0	95	
100							23.3	21.5	23.0	23.2	22.9	21.8	21.2	20.0	18.1	100	
110								19.7	20.5	20.1	19.5	18.4	17.3	16.0	15.6	110	
120									17.8	17.0	16.4	15.4	14.2	12.9	12.9	120	
130										14.4	13.7	12.7	11.5	10.3	10.2	130	
140											12.3	11.6	10.6	9.3	8.1	140	
150												9.6	8.8	7.5	6.3	150	
160													7.2	6.0	4.5	160	
170														5.6	4.5	3.0	170
180															3.5	180	

* Special Conditions Or Wire Rope Required
(1) Over Rear Only With Swing Lock Engaged

This information is not for crane operation. Operator must refer to the in-cab information for crane operation. Rated lifting capacities shown on fully extended outriggers do not exceed 85% of the tipping loads.

51,808 lb Counterweight – Fully Extended Outriggers – 360° Rotation (All Capacities Are Listed In Thousand Pounds)																
Radius (ft)	Boom Length (ft)													Radius (ft)		
	43.3 (1)	43.3	57.1	70.9	84.6	98.4	111.9	125.7	139.4	153.2	167.0	180.4	194.2		208.0	223.1
10	392.2*	359.1*	308.6*	308.6*	251.3*											10
12	334.8*	315.5*	303.8*	303.1*	247.5*	199.5										12
14	287.1*	280.2*	279.7*	276.9*	233.3	199.5										14
16	249.6*	248.8*	248.8*	246.3*	227.1	193.7	154.3									16
18	221.6	221.6	221.3	218.6	205.7	179.6	154.3	120.2								18
20	196.5	196.5	195.8	191.8	179.6	167.9	151.9	120.2	95.9							20
25	156.0	156.0	149.2	136.5	130.2	125.4	119.1	111.1	95.9	76.1						25
30	120.1	120.1	118.1	102.9	99.3	99.5	100.9	94.2	84.8	75.9	62.8	50.7				30
35			89.0	83.8	88.9	87.3	82.8	77.3	72.2	69.0	62.8	50.7	41.4			35
40			69.8	75.4	79.8	73.4	69.8	64.9	61.8	58.0	56.3	50.3	41.4	33.1	27.6	40
45			62.0	64.8	65.9	64.5	62.4	55.4	55.0	49.4	48.1	46.7	41.4	33.1	27.6	45
50				55.2	55.8	55.2	54.1	48.8	48.2	45.2	43.6	41.2	39.3	33.1	27.6	50
55				47.2	47.8	47.1	46.5	43.2	42.6	41.5	39.3	38.1	35.6	32.7	27.6	55
60				40.6	41.3	40.7	40.0	38.0	38.4	37.9	36.7	35.9	32.6	31.5	27.4	60
65					36.1	35.5	34.6	32.8	34.0	35.2	34.1	32.0	29.9	27.8	26.6	65
70					32.6	31.3	30.8	29.8	31.5	32.6	31.4	28.6	26.7	24.7	24.0	70
75						27.6	28.8	27.8	29.1	29.7	28.7	25.9	24.2	21.9	21.3	75
80						24.8	26.8	26.0	26.7	26.6	26.0	23.7	22.2	19.6	18.9	80
85						23.7	24.8	24.4	24.4	23.8	23.3	21.7	20.2	18.0	16.9	85
90							22.5	22.2	21.9	21.5	20.9	19.7	18.3	16.1	15.3	90
95							20.4	20.2	19.8	19.4	18.7	17.7	16.4	14.5	13.9	95
100							18.6	18.4	18.0	17.3	16.7	15.8	14.5	13.0	12.6	100
110								15.2	14.8	14.1	13.5	12.4	11.4	9.9	9.9	110
120									12.2	11.5	11.0	9.8	8.8	7.3	7.3	120
130										9.5	8.8	7.6	6.6	5.1	5.1	130
140										7.6	7.0	5.9	4.8	3.4	3.4	140
150											5.4	4.3	3.2			150
160												3.0				160

* Special Conditions Or Wire Rope Required
(1) Over Rear Only With Swing Lock Engaged

This information is not for crane operation. Operator must refer to the in-cab information for crane operation. Rated lifting capacities shown on fully extended outriggers do not exceed 85% of the tipping loads.

26,455 lb Counterweight – Fully Extended Outriggers – 360° Rotation (All Capacities Are Listed In Thousand Pounds)																
Radius (ft)	Boom Length (ft)													Radius (ft)		
	43.3 (1)	43.3	57.1	70.9	84.6	98.4	111.9	125.7	139.4	153.2	167.0	180.4	194.2		208.0	223.1
10	377.4*	348.0*	308.6*	308.6*	251.3*										10	
12	316.7*	304.4*	300.3*	299.6*	247.5*	199.5									12	
14	271.1*	268.0*	267.5*	265.3*	233.3	199.5									14	
16	235.0	233.9	233.9	228.0	208.0	184.7	154.3								16	
18	208.1	207.5	205.4	192.1	177.7	159.4	143.4	120.2							18	
20	183.9	183.7	178.6	159.3	149.3	141.7	129.4	118.6	95.9						20	
25	133.4	133.4	126.4	112.2	107.1	107.8	104.5	93.7	87.4	76.1					25	
30	92.7	92.7	91.2	90.1	94.7	89.1	83.9	77.9	72.0	68.5	62.2	50.7			30	
35			72.9	76.9	78.3	72.4	68.3	63.1	62.7	55.1	53.3	50.3	41.4		35	
40			58.7	61.3	60.2	59.8	56.5	52.1	52.1	49.5	47.6	43.2	40.8	33.1	27.6	40
45			46.9	49.6	50.0	49.3	48.3	45.7	45.3	45.3	41.7	38.5	36.0	33.1	27.6	45
50				41.0	41.6	41.0	40.2	39.8	41.3	41.8	39.6	34.9	32.0	30.5	27.6	50
55				34.3	36.5	34.3	36.5	36.2	36.8	37.0	35.9	32.3	30.2	27.4	25.9	55
60				29.0	31.2	31.5	32.3	32.2	32.0	31.6	31.1	29.7	27.8	24.7	22.7	60
65					27.0	27.6	28.1	27.9	27.7	27.2	26.8	25.6	24.4	22.1	20.6	65
70					23.7	24.2	24.8	24.5	24.3	23.7	23.3	22.2	20.9	19.2	18.4	70
75						21.2	21.9	21.6	21.3	20.7	20.3	19.1	17.9	16.3	16.1	75
80						18.6	19.2	19.0	18.6	18.1	17.7	16.4	15.3	13.8	13.7	80
85						16.4	16.9	16.7	16.4	15.6	15.1	14.2	12.9	11.6	11.4	85
90							15.0	14.8	14.6	13.7	13.3	12.2	11.1	9.7	9.5	90
95							13.4	13.1	12.8	12.1	11.5	10.5	9.3	8.0	7.9	95
100							11.9	11.5	11.3	10.6	10.0	9.0	7.8	6.4	6.4	100
110								9.1	8.6	8.1	7.5	6.5	5.3	3.7	3.7	110
120									6.8	6.0	5.4	4.2	3.4			120
130										4.4	3.6	2.6				130
140											2.9					140

* Special Conditions Or Wire Rope Required
(1) Over Rear Only With Swing Lock Engaged

This information is not for crane operation. Operator must refer to the in-cab information for crane operation. Rated lifting capacities shown on fully extended outriggers do not exceed 85% of the tipping loads.

0 lb Counterweight – Fully Extended Outriggers – 360° Rotation (All Capacities Are Listed In Thousand Pounds)														
Radius (ft)	Boom Length (ft)												Radius (ft)	
	43.3 (1)	43.3	57.1	70.9	84.6	98.4	111.9	125.7	139.4	153.2	167.0	180.4		194.2
10	355.7*	334.9*	307.9*	307.7*	251.3*									10
12	298.0*	292.0*	290.9*	281.7*	237.7	195.3								12
14	253.0*	253.0*	247.8*	218.7	195.2	169.4								14
16	218.8	218.8	197.7	170.4	155.5	144.6	128.9							16
18	183.0	183.0	161.4	140.7	130.3	122.6	115.2	105.1						18
20	148.7	148.7	131.0	115.5	113.6	115.5	106.2	94.2	83.0					20
25	101.5	101.5	91.4	93.2	90.0	83.7	77.3	69.8	65.8	58.8				25
30	67.7	67.7	73.9	74.1	67.5	62.8	58.2	56.8	54.8	51.4	46.6	41.9		30
35			53.5	57.0	55.8	51.4	50.8	49.2	46.9	43.9	40.5	37.1	33.1	35
40			40.8	44.5	46.9	43.6	45.0	40.9	39.1	36.7	34.6	32.0	29.6	40
45			32.1	35.4	38.0	38.3	38.1	36.2	34.8	32.7	29.0	26.8	24.5	45
50				28.7	31.2	32.1	32.4	31.0	30.1	28.3	25.4	23.2	21.1	50
55				23.4	25.8	26.6	27.4	26.2	25.9	24.3	22.4	20.3	18.4	55
60				19.0	21.6	22.3	23.0	21.9	22.4	21.0	19.6	17.8	15.8	60
65					18.1	18.9	19.6	18.5	19.3	18.0	16.9	15.1	13.1	65
70					15.4	16.2	16.7	15.7	16.3	15.6	14.6	12.9	11.0	70
75						13.8	14.3	13.4	13.8	13.3	12.5	10.9	9.1	75
80						11.7	12.3	11.5	11.7	11.2	10.6	9.1	7.3	80
85						10.0	10.5	9.8	10.0	9.4	8.9	7.6	5.8	85
90							9.1	8.3	8.5	7.8	7.4	6.1		90
95							7.9	7.0	7.2	6.4	6.0	4.8		95
100							6.7	5.9	6.0	5.2	4.8	3.6		100
110								4.0	4.0	3.2				110

* Special Conditions Or Wire Rope Required
(1) Over Rear Only With Swing Lock Engaged

This information is not for crane operation. Operator must refer to the in-cab information for crane operation. Rated lifting capacities shown on fully extended outriggers do not exceed 85% of the tipping loads.

Fly Attachment Lift Capacity Charts – Optional

156,527 lb Counterweight – Fully Extended Outriggers – 360° Rotation (All Capacities Are Listed In Thousand Pounds)													
43.3 ft Main Boom Length				111.9 ft Main Boom Length			208.0 ft Main Boom Length			223.1 ft Main Boom Length			
Radius (ft)	17.7 ft Offset Fly			17.7 ft Offset Fly			17.7 ft Offset Fly			17.7 ft Offset Fly			Radius (ft)
	0°	20°	40°	0°	20°	40°	0°	20°	40°	0°	20°	40°	
10	104.2												10
12	97.5	66.3											12
14	91.6	63.8											14
16	86.4	61.3											16
18	81.9	59.2	48.1										18
20	77.7	57.3	47.0	85.3									20
25	69.2	53.2	44.8	85.3									25
30	62.3	49.8	43.1	85.2	60.8	47.3							30
35	56.7	47.0	41.7	81.7	58.5	46.3							35
40	51.6	44.0	40.2	75.4	56.2	45.3							40
45	46.6	41.3		69.8	54.4	44.5							45
50	42.1			64.8	52.6	43.6	23.2			20.3			50
55				60.4	51.1	42.9	22.3	20.7	19.9	20.0	19.1		55
60				56.4	49.6	42.2	21.4	19.9	19.3	19.5	18.4	17.7	60
65				52.9	48.2	41.7	20.6	19.3	18.6	18.8	17.7	17.1	65
70				49.8	47.0	41.1	19.9	18.6	18.1	18.2	17.2	16.5	70
75				47.0	45.6	40.4	19.2	18.0	17.5	17.6	16.7	16.0	75
80				44.3	43.8	39.8	18.6	17.5	16.8	17.1	16.2	15.6	80
85				41.4	41.6	39.5	17.9	17.0	16.3	16.6	15.7	15.2	85
90				38.9	39.6	39.0	17.4	16.7	16.0	16.1	15.3	14.9	90
95				35.9	36.7	36.8	16.9	16.2	15.7	15.6	14.9	14.6	95
100				32.8	33.4	33.6	16.4	15.8	15.3	15.1	14.4	14.2	100
110				27.2	27.7		15.5	14.9	14.7	14.2	13.8	13.6	110
120				22.8			14.6	14.2	14.0	13.5	13.1	12.9	120
130							14.0	13.5	13.3	12.9	12.4	12.2	130
140							13.4	13.0	12.8	12.3	11.9	11.7	140
150							12.7	12.4	12.3	11.8	11.5	11.3	150
160							11.7	11.7	11.7	11.3	11.1	10.9	160
170							10.9	10.9	10.9	10.4	10.4	10.4	170
180							10.0	10.0		9.7	9.7	9.7	180
190							9.1	9.3		9.1	9.1	9.1	190
200							8.1	8.6		8.2	8.2		200
210							7.1			7.1	7.1		210
220										5.9			220

This information is not for crane operation. Operator must refer to the in-cab information for crane operation. Rated lifting capacities shown on fully extended outriggers do not exceed 85% of the tipping loads.

156,527 lb Counterweight – Fully Extended Outriggers – 360° Rotation (All Capacities Are Listed In Thousand Pounds)																
43.3 ft Main Boom Length																
Radius (ft)	43.3 ft Offset Fly			63.0 ft Offset Fly			82.7 ft Offset Fly			102.4 ft Offset Fly			122.0 ft Offset Fly			Radius (ft)
	0°	20°	40°	0°	20°	40°	0°	20°	40°	0°	20°	40°	0°	20°	40°	
10	39.7															10
12	39.7			35.1												12
14	39.0			34.3			22.9									14
16	37.2			33.3			22.9									16
18	35.4			32.3			22.9			14.1						18
20	33.7			31.4			22.9			14.1			10.1			20
25	30.4	24.5		29.2			22.9			14.1			10.1			25
30	27.6	22.5		27.1			21.9			14.1			10.1			30
35	25.2	21.0		24.9			20.2			14.1			10.1			35
40	23.2	19.7	17.3	22.9	18.8		18.8			14.1			10.1			40
45	21.5	18.5	16.5	21.3	17.6		17.4			13.9			10.1			45
50	20.1	17.6	15.9	19.9	16.3		16.2			13.2			10.0			50
55	18.8	16.8	15.4	18.4	15.1	12.7	15.1	12.9		12.4			9.7			55
60	17.7	16.0	15.0	16.9	14.1	12.0	14.2	12.2		11.8			9.2			60
65	16.7	15.3	14.8	15.6	13.1	11.5	13.3	11.1		11.1			8.9			65
70	15.9	14.9		14.4	12.4	11.0	12.5	10.4		10.4			8.4			70
75	15.3	14.6		13.3	11.7	10.5	11.6	9.8		9.9	8.3		8.0			75
80				12.4	11.1	10.1	10.6	9.1		9.3	7.8		7.6	6.7		80
85				11.5	10.4	9.7	10.0	8.6	7.7	8.4	7.3		7.3	6.4		85
90				10.7	10.0		9.3	8.1	7.4	7.9	6.8		7.0	5.9		90
95							8.6	7.7	7.1	7.4	6.4		6.5	5.5		95
100							8.0	7.4	6.8	6.9	6.1		6.0	5.2		100
110							7.2	6.7	6.4	6.1	5.4	5.0	5.2	4.7		110
120										5.4	5.0	4.6	4.6	4.1	3.7	120
130										4.7	4.5	4.2	4.1	3.8	3.3	130
140													3.5	3.5	3.2	140
150													3.1	3.1	3.0	150

This information is not for crane operation. Operator must refer to the in-cab information for crane operation. Rated lifting capacities shown on fully extended outriggers do not exceed 85% of the tipping loads.

156,527 lb Counterweight – Fully Extended Outriggers – 360° Rotation (All Capacities Are Listed In Thousand Pounds)																
111.9 ft Main Boom Length																
Radius (ft)	43.3 ft Offset Fly			63.0 ft Offset Fly			82.7 ft Offset Fly			102.4 ft Offset Fly			122.0 ft Offset Fly			Radius (ft)
	0°	20°	40°	0°	20°	40°	0°	20°	40°	0°	20°	40°	0°	20°	40°	
20	39.3															20
25	36.8			28.9												25
30	34.6			28.8			19.6			12.6						30
35	32.4			28.0			19.6			12.6			9.0			35
40	30.7	22.4		27.0			19.6			12.6			9.0			40
45	29.0	21.4		25.8			19.4			12.6			9.0			45
50	27.4	20.5		24.6			18.9			12.6			9.0			50
55	26.1	19.7	16.5	23.5	17.7		18.1			12.6			9.0			55
60	24.9	19.1	16.0	22.5	17.1		17.3			12.6			9.0			60
65	23.7	18.4	15.7	21.5	16.4	12.8	16.6	12.6		12.6			9.0			65
70	22.7	17.9	15.4	20.5	15.9	12.5	15.9	12.1		12.1			9.0			70
75	21.8	17.4	15.1	19.7	15.4	12.2	15.3	11.7		11.7			8.8			75
80	21.0	16.9	14.9	19.0	14.9	11.8	14.6	11.4		11.4	9.0		8.6			80
85	20.1	16.6	14.6	18.1	14.4	11.5	13.9	11.0		11.0	8.6		8.4			85
90	19.4	16.1	14.4	17.4	13.9	11.1	13.4	10.7		10.5	8.3		8.1			90
95	18.8	15.7	14.2	16.9	13.4	10.9	12.9	10.4	8.3	10.2	8.1		7.7			95
100	18.1	15.3	14.1	16.3	12.8	10.7	12.5	10.0	8.1	9.8	7.8		7.4	6.1		100
110	16.9	14.8	13.9	15.1	12.0	10.2	11.6	9.4	7.5	9.1	7.3	5.8	7.1	5.8		110
120	16.1	14.3	13.9	13.9	11.3	9.9	10.9	8.7	7.2	8.5	6.7	5.4	6.6	5.4		120
130	15.3	13.9		12.7	10.6	9.5	10.0	8.0	6.9	8.0	6.2	5.1	6.2	4.9	4.0	130
140	14.9			11.7	10.1		9.2	7.6	6.7	7.3	5.9	4.9	5.9	4.6	3.7	140
150				10.8	9.7		8.4	7.2	6.5	6.7	5.5	4.8	5.4	4.2	3.4	150
160				9.9	9.4		7.8	6.7	6.4	6.0	5.2	4.6	4.9	3.9	3.3	160
170							7.1	6.4		5.5	4.9	4.4	4.4	3.8	3.1	170
180							6.6			5.2	4.5		4.1	3.4	3.1	180
190										4.8	4.3		3.8	3.2	3.0	190
200										4.3	4.1		3.5	3.0	2.8	200
210													3.3	2.9		210
220													3.0			220

This information is not for crane operation. Operator must refer to the in-cab information for crane operation. Rated lifting capacities shown on fully extended outriggers do not exceed 85% of the tipping loads.

156,527 lb Counterweight – Fully Extended Outriggers – 360° Rotation (All Capacities Are Listed In Thousand Pounds)															
208.0 ft Main Boom Length															
Radius (ft)	43.3 ft Offset Fly			63.0 ft Offset Fly			82.7 ft Offset Fly			102.4 ft Offset Fly			122.0 ft Offset Fly		Radius (ft)
	0°	20°	40°	0°	20°	40°	0°	20°	40°	0°	20°	40°	0°	20°	
45	15.0														45
50	15.0			11.5											50
55	15.0			11.5			8.8								55
60	15.0			11.5			8.8			7.1					60
65	15.0	14.8		11.5			8.8			7.1			5.5		65
70	15.0	14.3		11.5			8.8			7.1			5.5		70
75	15.0	13.9		11.5	11.4		8.8			7.1			5.5		75
80	14.9	13.6	12.5	11.5	11.2		8.8			7.1			5.5		80
85	14.8	13.2	12.1	11.5	10.8		8.8	8.8		7.1			5.5		85
90	14.3	12.9	12.0	11.5	10.5		8.8	8.7		7.1			5.5		90
95	13.9	12.6	11.7	11.5	10.2		8.8	8.5		7.1			5.5		95
100	13.5	12.2	11.4	11.4	9.9	9.2	8.8	8.3		7.1	6.6		5.5		100
110	12.7	11.6	10.9	10.7	9.5	8.7	8.8	7.8	7.1	7.1	6.4		5.5	4.6	110
120	12.1	11.0	10.5	10.1	9.0	8.3	8.5	7.4	6.8	7.1	6.1		5.4	4.6	120
130	11.5	10.4	10.0	9.6	8.6	8.0	8.2	7.1	6.6	6.9	5.8	5.3	5.3	4.4	130
140	11.0	10.1	9.6	9.2	8.3	7.6	7.7	6.8	6.3	6.4	5.4	5.1	5.1	4.3	140
150	10.5	9.7	9.3	8.8	8.0	7.4	7.3	6.4	6.1	6.1	5.2	4.9	5.0	4.1	150
160	10.1	9.4	9.0	8.3	7.6	7.2	7.0	6.1	5.9	5.9	5.0	4.6	4.8	3.9	160
170	9.7	9.1	8.8	8.0	7.3	7.1	6.6	6.0	5.5	5.5	4.9	4.4	4.6	3.8	170
180	9.1	8.7	8.7	7.8	7.0	6.7	6.3	5.8	5.4	5.2	4.5	4.3	4.3	3.6	180
190	8.5	8.4	8.3	7.5	6.7	6.5	6.1	5.5	5.2	5.0	4.3	4.1	4.1	3.4	190
200	8.0	8.0	7.8	7.1	6.6	6.3	5.9	5.2	5.0	4.7	4.1	3.9	3.9	3.3	200
210	7.5	7.5		6.6	6.4	6.2	5.7	5.1	4.8	4.4	4.0	3.7	3.7	3.1	210
220	6.8	7.0		6.3	6.1	6.0	5.4	4.9	4.7	4.2	3.8	3.6	3.4	3.1	220
230	6.0	6.3		5.8	5.7		5.1	4.7	4.5	4.1	3.6	3.4	3.2	3.0	230
240				5.3	5.4		4.7	4.6	4.3	3.8	3.5	3.2	3.0	2.8	240
250				4.8	5.0		4.4	4.4		3.5	3.3	3.1	2.9		250
260							4.1	4.2		3.3	3.1	2.9			260
270							3.5	3.7		3.1	3.0				270
280							2.8	3.0		2.7	2.8				280

This information is not for crane operation. Operator must refer to the in-cab information for crane operation. Rated lifting capacities shown on fully extended outriggers do not exceed 85% of the tipping loads.

156,527 lb Counterweight – Fully Extended Outriggers – 360° Rotation (All Capacities Are Listed In Thousand Pounds)														
223.1 ft Main Boom Length														
Radius (ft)	43.3 ft Offset Fly			63.0 ft Offset Fly			82.7 ft Offset Fly			102.4 ft Offset Fly			122.0 ft Offset Fly	Radius (ft)
	0°	20°	40°	0°	20°	40°	0°	20°	40°	0°	20°	40°	0°	
50	13.0													50
55	13.0			10.1										55
60	13.0			10.1										60
65	13.0	13.0		10.1			7.9			6.2				65
70	13.0	13.0		10.1			7.9			6.2			5.1	70
75	13.0	12.9		10.1			7.9			6.2			5.1	75
80	13.0	12.7	11.8	10.1	10.1		7.9			6.2			5.1	80
85	13.0	12.4	11.5	10.1	10.1		7.9			6.2			5.1	85
90	13.0	12.0	11.1	10.1	9.8		7.9			6.2			5.1	90
95	12.8	11.7	10.9	10.1	9.6		7.9	7.9		6.2			5.1	95
100	12.5	11.4	10.7	10.1	9.4	8.5	7.9	7.8		6.2			5.1	100
110	11.8	10.7	10.2	10.0	8.9	8.2	7.9	7.3		6.2	6.0		5.1	110
120	11.3	10.2	9.8	9.4	8.5	7.9	7.9	7.0	6.6	6.2	5.7		5.1	120
130	10.7	9.7	9.3	8.9	8.0	7.5	7.5	6.7	6.2	6.2	5.6		5.1	130
140	10.1	9.4	9.0	8.5	7.6	7.2	7.2	6.3	5.9	6.0	5.2		4.9	140
150	9.7	9.1	8.6	8.2	7.3	7.0	6.9	6.1	5.6	5.8	5.0	4.5	4.8	150
160	9.4	8.7	8.3	7.9	7.0	6.7	6.5	5.9	5.5	5.4	4.8	4.4	4.5	160
170	8.8	8.4	8.2	7.5	6.8	6.4	6.2	5.5	5.3	5.1	4.4	4.2	4.2	170
180	8.5	8.1	7.8	7.2	6.5	6.2	5.9	5.4	5.1	4.8	4.3	4.1	4.0	180
190	8.2	7.8	7.6	6.8	6.3	6.1	5.6	5.1	5.0	4.5	4.1	3.9	3.9	190
200	7.7	7.6	7.4	6.6	6.1	5.9	5.5	4.8	4.8	4.4	3.9	3.7	3.6	200
210	7.1	7.3	7.3	6.4	6.0	5.7	5.3	4.6	4.6	4.2	3.7	3.5	3.3	210
220	6.5	6.8		6.1	5.8	5.6	5.1	4.6	4.5	4.0	3.6	3.4	3.1	220
230	5.8	6.0		5.6	5.6	5.5	4.8	4.5	4.3	3.9	3.4	3.2	3.0	230
240	5.0	5.2		5.1	5.3		4.5	4.3	4.1	3.7	3.2	3.0	2.8	240
250	4.1	4.4		4.6	4.8		4.2	4.2	4.0	3.5	3.1	2.9		250
260				3.9	4.1		3.8	4.0		3.2	2.9			260
270								3.7						270
280								3.4						280

This information is not for crane operation. Operator must refer to the in-cab information for crane operation. Rated lifting capacities shown on fully extended outriggers do not exceed 85% of the tipping loads.

103,616 lb Counterweight – Fully Extended Outriggers – 360° Rotation (All Capacities Are Listed In Thousand Pounds)													
43.3 ft Main Boom Length				111.9 ft Main Boom Length			208.0 ft Main Boom Length			223.1 ft Main Boom Length			
Radius (ft)	17.7 ft Offset Fly			17.7 ft Offset Fly			17.7 ft Offset Fly			17.7 ft Offset Fly			Radius (ft)
	0°	20°	40°	0°	20°	40°	0°	20°	40°	0°	20°	40°	
10	104.2												10
12	97.5	66.3											12
14	91.6	63.8											14
16	86.4	61.3											16
18	81.9	59.2	48.1										18
20	77.7	57.3	47.0	85.3									20
25	69.2	53.2	44.8	85.3									25
30	62.3	49.8	43.1	85.2	60.8	47.3							30
35	56.7	47.0	41.7	81.7	58.5	46.3							35
40	51.6	44.0	40.2	75.4	56.2	45.3							40
45	46.6	41.3		69.8	54.4	44.5							45
50	42.1			64.8	52.6	43.6	23.2			20.3			50
55				58.4	51.1	42.9	22.3	20.7	19.9	20.0	19.1		55
60				50.8	49.1	42.2	21.4	19.9	19.3	19.5	18.4	17.7	60
65				44.0	45.2	41.7	20.6	19.3	18.6	18.8	17.7	17.1	65
70				38.5	39.9	39.5	19.9	18.6	18.1	18.2	17.2	16.5	70
75				33.8	35.7	36.6	19.2	18.0	17.5	17.6	16.7	16.0	75
80				29.8	32.6	33.5	18.6	17.5	16.8	17.1	16.2	15.6	80
85				26.2	29.7	30.6	17.9	17.0	16.3	16.6	15.7	15.2	85
90				24.1	26.4	27.1	17.4	16.7	16.0	16.1	15.3	14.9	90
95				22.2	23.4	23.9	16.9	16.2	15.7	15.6	14.9	14.6	95
100				20.2	20.9	20.9	16.4	15.8	15.3	15.1	14.4	14.2	100
110				15.8	16.2		15.5	14.9	14.7	14.2	13.8	13.6	110
120				12.4			14.6	14.2	14.0	13.5	13.1	12.9	120
130							13.6	13.5	13.3	12.9	12.4	12.2	130
140							11.2	11.5	11.8	11.2	11.6	11.5	140
150							9.1	9.4	9.8	9.3	10.1	10.1	150
160							7.3	7.6	7.8	7.5	8.1	8.2	160
170							5.6	6.3	6.3	5.8	6.3	6.5	170
180							4.4	4.8		4.6	4.9	5.0	180
190										3.5	3.6	3.5	190

This information is not for crane operation. Operator must refer to the in-cab information for crane operation. Rated lifting capacities shown on fully extended outriggers do not exceed 85% of the tipping loads.

103,616 lb Counterweight – Fully Extended Outriggers – 360° Rotation (All Capacities Are Listed In Thousand Pounds)																
43.3 ft Main Boom Length																
Radius (ft)	43.3 ft Offset Fly			63.0 ft Offset Fly			82.7 ft Offset Fly			102.4 ft Offset Fly			122.0 ft Offset Fly			Radius (ft)
	0°	20°	40°	0°	20°	40°	0°	20°	40°	0°	20°	40°	0°	20°	40°	
10	39.7															10
12	39.7			35.1												12
14	39.0			34.3			22.9									14
16	37.2			33.3			22.9									16
18	35.4			32.3			22.9			14.1						18
20	33.7			31.4			22.9			14.1			10.1			20
25	30.4	24.5		29.2			22.9			14.1			10.1			25
30	27.6	22.5		27.1			21.9			14.1			10.1			30
35	25.2	21.0		24.9			20.2			14.1			10.1			35
40	23.2	19.7	17.3	22.9	18.8		18.8			14.1			10.1			40
45	21.5	18.5	16.5	21.3	17.6		17.4			13.9			10.1			45
50	20.1	17.6	15.9	19.9	16.3		16.2			13.2			10.0			50
55	18.8	16.8	15.4	18.4	15.1	12.7	15.1	12.9		12.4			9.7			55
60	17.7	16.0	15.0	16.9	14.1	12.0	14.2	12.2		11.8			9.2			60
65	16.7	15.3	14.8	15.6	13.1	11.5	13.3	11.1		11.1			8.9			65
70	15.9	14.9		14.4	12.4	11.0	12.5	10.4		10.4			8.4			70
75	15.3	14.6		13.3	11.7	10.5	11.6	9.8		9.9	8.3		8.0			75
80				12.4	11.1	10.1	10.6	9.1		9.3	7.8		7.6	6.7		80
85				11.5	10.4	9.7	10.0	8.6	7.7	8.4	7.3		7.3	6.4		85
90				10.7	10.0		9.3	8.1	7.4	7.9	6.8		7.0	5.9		90
95							8.6	7.7	7.1	7.4	6.4		6.5	5.5		95
100							8.0	7.4	6.8	6.9	6.1		6.0	5.2		100
110							7.2	6.7	6.4	6.1	5.4	5.0	5.2	4.7		110
120										5.4	5.0	4.6	4.6	4.1	3.7	120
130										4.7	4.5	4.2	4.1	3.8	3.3	130
140													3.5	3.5	3.2	140
150													3.1	3.1	3.0	150

This information is not for crane operation. Operator must refer to the in-cab information for crane operation. Rated lifting capacities shown on fully extended outriggers do not exceed 85% of the tipping loads.

103,616 lb Counterweight – Fully Extended Outriggers – 360° Rotation (All Capacities Are Listed In Thousand Pounds)																
111.9 ft Main Boom Length																
Radius (ft)	43.3 ft Offset Fly			63.0 ft Offset Fly			82.7 ft Offset Fly			102.4 ft Offset Fly			122.0 ft Offset Fly			Radius (ft)
	0°	20°	40°	0°	20°	40°	0°	20°	40°	0°	20°	40°	0°	20°	40°	
20	39.3															20
25	36.8			28.9												25
30	34.6			28.8			19.6			12.6						30
35	32.4			28.0			19.6			12.6			9.0			35
40	30.7	22.4		27.0			19.6			12.6			9.0			40
45	29.0	21.4		25.8			19.4			12.6			9.0			45
50	27.4	20.5		24.6			18.9			12.6			9.0			50
55	26.1	19.7	16.5	23.5	17.7		18.1			12.6			9.0			55
60	24.9	19.1	16.0	22.5	17.1		17.3			12.6			9.0			60
65	23.7	18.4	15.7	21.5	16.4	12.8	16.6	12.6		12.6			9.0			65
70	22.7	17.9	15.4	20.5	15.9	12.5	15.9	12.1		12.1			9.0			70
75	21.8	17.4	15.1	19.7	15.4	12.2	15.3	11.7		11.7			8.8			75
80	21.0	16.9	14.9	19.0	14.9	11.8	14.6	11.4		11.4	9.0		8.6			80
85	20.1	16.6	14.6	18.1	14.4	11.5	13.9	11.0		11.0	8.6		8.4			85
90	19.4	16.1	14.4	17.4	13.9	11.1	13.4	10.7		10.5	8.3		8.1			90
95	18.8	15.7	14.2	16.9	13.4	10.9	12.9	10.4	8.3	10.2	8.1		7.7			95
100	18.1	15.3	14.1	16.3	12.8	10.7	12.5	10.0	8.1	9.8	7.8		7.4	6.1		100
110	16.9	14.8	13.9	15.1	12.0	10.2	11.6	9.4	7.5	9.1	7.3	5.8	7.1	5.8		110
120	15.7	14.3	13.9	13.9	11.3	9.9	10.9	8.7	7.2	8.5	6.7	5.4	6.6	5.4		120
130	12.9	13.8		12.7	10.6	9.5	10.0	8.0	6.9	8.0	6.2	5.1	6.2	4.9	4.0	130
140	10.5			11.5	10.1		9.2	7.6	6.7	7.3	5.9	4.9	5.9	4.6	3.7	140
150				10.0	9.6		8.4	7.2	6.5	6.7	5.5	4.8	5.4	4.2	3.4	150
160				8.1	9.1		7.8	6.7	6.4	6.0	5.2	4.6	4.9	3.9	3.3	160
170							7.1	6.4		5.5	4.9	4.4	4.4	3.8	3.1	170
180							5.9			5.2	4.5		4.1	3.4	3.1	180
190										4.8	4.3		3.8	3.2	3.0	190
200										4.3	4.1		3.5	3.0	2.8	200
210													3.3	2.9		210
220													3.0			220

This information is not for crane operation. Operator must refer to the in-cab information for crane operation. Rated lifting capacities shown on fully extended outriggers do not exceed 85% of the tipping loads.

103,616 lb Counterweight – Fully Extended Outriggers – 360° Rotation (All Capacities Are Listed In Thousand Pounds)															
208.0 ft Main Boom Length															
Radius (ft)	43.3 ft Offset Fly			63.0 ft Offset Fly			82.7 ft Offset Fly			102.4 ft Offset Fly			122.0 ft Offset Fly		Radius (ft)
	0°	20°	40°	0°	20°	40°	0°	20°	40°	0°	20°	40°	0°	20°	
45	15.0														45
50	15.0			11.5											50
55	15.0			11.5			8.8								55
60	15.0			11.5			8.8			7.1					60
65	15.0	14.8		11.5			8.8			7.1			5.5		65
70	15.0	14.3		11.5			8.8			7.1			5.5		70
75	15.0	13.9		11.5	11.4		8.8			7.1			5.5		75
80	14.9	13.6	12.5	11.5	11.2		8.8			7.1			5.5		80
85	14.8	13.2	12.1	11.5	10.8		8.8	8.8		7.1			5.5		85
90	14.3	12.9	12.0	11.5	10.5		8.8	8.7		7.1			5.5		90
95	13.9	12.6	11.7	11.5	10.2		8.8	8.5		7.1			5.5		95
100	13.5	12.2	11.4	11.4	9.9	9.2	8.8	8.3		7.1	6.6		5.5		100
110	12.7	11.6	10.9	10.7	9.5	8.7	8.8	7.8	7.1	7.1	6.4		5.5	4.6	110
120	12.1	11.0	10.5	10.1	9.0	8.3	8.5	7.4	6.8	7.1	6.1		5.5	4.6	120
130	11.5	10.4	10.0	9.6	8.6	8.0	8.2	7.1	6.6	7.1	5.8	5.3	5.4	4.4	130
140	11.0	10.1	9.6	9.2	8.3	7.6	7.7	6.8	6.3	6.9	5.4	5.1	5.3	4.3	140
150	10.2	9.7	9.3	8.8	8.0	7.4	7.3	6.4	6.1	6.4	5.2	4.9	5.1	4.1	150
160	9.1	9.2	9.0	8.3	7.6	7.2	7.0	6.1	5.9	6.1	5.0	4.6	5.0	3.9	160
170	7.4	8.2	8.8	7.7	7.3	7.1	6.6	6.0	5.5	5.9	4.9	4.4	4.8	3.8	170
180	6.0	6.9	7.4	6.3	7.0	6.7	6.3	5.8	5.4	5.5	4.5	4.3	4.6	3.6	180
190	4.8	5.6	6.0	5.1	6.1	6.4	5.5	5.5	5.2	5.2	4.3	4.1	4.3	3.4	190
200	3.6	4.3	4.6	4.0	5.0	5.7	4.6	5.2	5.0	5.0	4.1	3.9	4.1	3.3	200
210		3.1		2.9	4.0	4.4	3.7	4.8	4.8	4.6	4.0	3.7	3.9	3.1	210
220					3.0	3.2	2.9	3.7	4.3	3.7	3.8	3.6	3.7	3.1	220
230												3.4		3.0	230

This information is not for crane operation. Operator must refer to the in-cab information for crane operation. Rated lifting capacities shown on fully extended outriggers do not exceed 85% of the tipping loads.

103,616 lb Counterweight – Fully Extended Outriggers – 360° Rotation (All Capacities Are Listed In Thousand Pounds)														
223.1 ft Main Boom Length														
Radius (ft)	43.3 ft Offset Fly			63.0 ft Offset Fly			82.7 ft Offset Fly			102.4 ft Offset Fly			122.0 ft Offset Fly	Radius (ft)
	0°	20°	40°	0°	20°	40°	0°	20°	40°	0°	20°	40°	0°	
50	13.0													50
55	13.0			10.1										55
60	13.0			10.1										60
65	13.0	13.0		10.1			7.9			6.2				65
70	13.0	13.0		10.1			7.9			6.2			5.1	70
75	13.0	12.9		10.1			7.9			6.2			5.1	75
80	13.0	12.7	11.8	10.1	10.1		7.9			6.2			5.1	80
85	13.0	12.4	11.5	10.1	10.1		7.9			6.2			5.1	85
90	13.0	12.0	11.1	10.1	9.8		7.9			6.2			5.1	90
95	12.8	11.7	10.9	10.1	9.6		7.9	7.9		6.2			5.1	95
100	12.5	11.4	10.7	10.1	9.4	8.5	7.9	7.8		6.2			5.1	100
110	11.8	10.7	10.2	10.0	8.9	8.2	7.9	7.3		6.2	6.0		5.1	110
120	11.3	10.2	9.8	9.4	8.5	7.9	7.9	7.0	6.6	6.2	5.7		5.1	120
130	10.7	9.7	9.3	8.9	8.0	7.5	7.5	6.7	6.2	6.2	5.6		5.1	130
140	10.1	9.4	9.0	8.5	7.6	7.2	7.2	6.3	5.9	6.0	5.2		4.9	140
150	9.6	9.1	8.6	8.2	7.3	7.0	6.9	6.1	5.6	5.8	5.0	4.5	4.8	150
160	8.8	8.6	8.3	7.9	7.0	6.7	6.5	5.9	5.5	5.4	4.8	4.4	4.5	160
170	7.2	8.0	8.2	7.5	6.8	6.4	6.2	5.5	5.3	5.1	4.4	4.2	4.2	170
180	5.8	6.7	7.2	6.5	6.5	6.2	5.9	5.4	5.1	4.8	4.3	4.1	4.0	180
190	4.6	5.3	5.9	5.3	6.0	6.1	5.2	5.1	5.0	4.5	4.1	3.9	3.9	190
200	3.4	4.0	4.5	4.0	5.1	5.6	4.3	4.8	4.8	4.1	3.9	3.7	3.6	200
210		2.9	3.3	2.9	4.0	4.6	3.3	4.6	4.6	3.3	3.7	3.5	3.3	210
220						3.5		3.6	4.3		3.6	3.4		220
230												3.2		230

This information is not for crane operation. Operator must refer to the in-cab information for crane operation. Rated lifting capacities shown on fully extended outriggers do not exceed 85% of the tipping loads.

77,161 lb Counterweight – Fully Extended Outriggers – 360° Rotation (All Capacities Are Listed In Thousand Pounds)													
43.3 ft Main Boom Length				111.9 ft Main Boom Length			208.0 ft Main Boom Length			223.1 ft Main Boom Length			
Radius (ft)	17.7 ft Offset Fly			17.7 ft Offset Fly			17.7 ft Offset Fly			17.7 ft Offset Fly			Radius (ft)
	0°	20°	40°	0°	20°	40°	0°	20°	40°	0°	20°	40°	
10	104.2												10
12	97.5	66.3											12
14	91.6	63.8											14
16	86.4	61.3											16
18	81.9	59.2	48.1										18
20	77.7	57.3	47.0	85.3									20
25	69.2	53.2	44.8	85.3									25
30	62.3	49.8	43.1	85.2	60.8	47.3							30
35	56.7	47.0	41.7	81.7	58.5	46.3							35
40	51.6	44.0	40.2	74.9	56.2	45.3							40
45	46.6	41.3		66.0	54.4	44.5							45
50	42.1			56.3	52.6	43.6	23.2			20.3			50
55				47.6	48.5	42.9	22.3	20.7	19.9	20.0	19.1		55
60				40.3	42.1	41.5	21.4	19.9	19.3	19.5	18.4	17.7	60
65				34.5	36.2	37.1	20.6	19.3	18.6	18.8	17.7	17.1	65
70				29.8	31.4	32.2	19.9	18.6	18.1	18.2	17.2	16.5	70
75				25.8	27.1	28.4	19.2	18.0	17.5	17.6	16.7	16.0	75
80				22.4	23.4	25.5	18.6	17.5	16.8	17.1	16.2	15.6	80
85				19.4	20.3	22.4	17.9	17.0	16.3	16.6	15.7	15.2	85
90				16.8	18.3	19.7	17.4	16.7	16.0	16.1	15.3	14.9	90
95				14.8	16.4	17.2	16.9	16.2	15.7	15.6	14.9	14.6	95
100				13.2	14.4	14.6	16.4	15.8	15.3	15.1	14.4	14.2	100
110				10.2	10.5		14.5	14.9	14.7	14.2	13.8	13.6	110
120				7.1			11.6	12.3	12.9	11.8	12.5	12.6	120
130							8.9	9.6	9.9	9.3	10.0	10.3	130
140							6.7	7.3	7.7	7.3	7.8	8.0	140
150							4.9	5.4	5.8	5.4	5.8	6.0	150
160							3.4	3.8	3.9	3.8	3.9	4.2	160

This information is not for crane operation. Operator must refer to the in-cab information for crane operation. Rated lifting capacities shown on fully extended outriggers do not exceed 85% of the tipping loads.

77,161 lb Counterweight – Fully Extended Outriggers – 360° Rotation (All Capacities Are Listed In Thousand Pounds)																
43.3 ft Main Boom Length																
Radius (ft)	43.3 ft Offset Fly			63.0 ft Offset Fly			82.7 ft Offset Fly			102.4 ft Offset Fly			122.0 ft Offset Fly			Radius (ft)
	0°	20°	40°	0°	20°	40°	0°	20°	40°	0°	20°	40°	0°	20°	40°	
10	39.7															10
12	39.7			35.1												12
14	39.0			34.3			22.9									14
16	37.2			33.3			22.9									16
18	35.4			32.3			22.9			14.1						18
20	33.7			31.4			22.9			14.1			10.1			20
25	30.4	24.5		29.2			22.9			14.1			10.1			25
30	27.6	22.5		27.1			21.9			14.1			10.1			30
35	25.2	21.0		24.9			20.2			14.1			10.1			35
40	23.2	19.7	17.3	22.9	18.8		18.8			14.1			10.1			40
45	21.5	18.5	16.5	21.3	17.6		17.4			13.9			10.1			45
50	20.1	17.6	15.9	19.9	16.3		16.2			13.2			10.0			50
55	18.8	16.8	15.4	18.4	15.1	12.7	15.1	12.9		12.4			9.7			55
60	17.7	16.0	15.0	16.9	14.1	12.0	14.2	12.2		11.8			9.2			60
65	16.7	15.3	14.8	15.6	13.1	11.5	13.3	11.1		11.1			8.9			65
70	15.9	14.9		14.4	12.4	11.0	12.5	10.4		10.4			8.4			70
75	15.3	14.6		13.3	11.7	10.5	11.6	9.8		9.9	8.3		8.0			75
80				12.4	11.1	10.1	10.6	9.1		9.3	7.8		7.6	6.7		80
85				11.5	10.4	9.7	10.0	8.6	7.7	8.4	7.3		7.3	6.4		85
90				10.7	10.0		9.3	8.1	7.4	7.9	6.8		7.0	5.9		90
95							8.6	7.7	7.1	7.4	6.4		6.5	5.5		95
100							8.0	7.4	6.8	6.9	6.1		6.0	5.2		100
110							7.2	6.7	6.4	6.1	5.4	5.0	5.2	4.7		110
120										5.4	5.0	4.6	4.6	4.1	3.7	120
130										4.7	4.5	4.2	4.1	3.8	3.3	130
140													3.5	3.5	3.2	140
150													3.1	3.1	3.0	150

This information is not for crane operation. Operator must refer to the in-cab information for crane operation. Rated lifting capacities shown on fully extended outriggers do not exceed 85% of the tipping loads.

77,161 lb Counterweight – Fully Extended Outriggers – 360° Rotation (All Capacities Are Listed In Thousand Pounds)																
111.9 ft Main Boom Length																
Radius (ft)	43.3 ft Offset Fly			63.0 ft Offset Fly			82.7 ft Offset Fly			102.4 ft Offset Fly			122.0 ft Offset Fly			Radius (ft)
	0°	20°	40°	0°	20°	40°	0°	20°	40°	0°	20°	40°	0°	20°	40°	
20	39.3															20
25	36.8			28.9												25
30	34.6			28.8			19.6			12.6						30
35	32.4			28.0			19.6			12.6			9.0			35
40	30.7	22.4		27.0			19.6			12.6			9.0			40
45	29.0	21.4		25.8			19.4			12.6			9.0			45
50	27.4	20.5		24.6			18.9			12.6			9.0			50
55	26.1	19.7	16.5	23.5	17.7		18.1			12.6			9.0			55
60	24.9	19.1	16.0	22.5	17.1		17.3			12.6			9.0			60
65	23.7	18.4	15.7	21.5	16.4	12.8	16.6	12.6		12.6			9.0			65
70	22.7	17.9	15.4	20.5	15.9	12.5	15.9	12.1		12.1			9.0			70
75	21.8	17.4	15.1	19.7	15.4	12.2	15.3	11.7		11.7			8.8			75
80	21.0	16.9	14.9	19.0	14.9	11.8	14.6	11.4		11.4	9.0		8.6			80
85	20.1	16.6	14.6	18.1	14.4	11.5	13.9	11.0		11.0	8.6		8.4			85
90	19.4	16.1	14.4	17.4	13.9	11.1	13.4	10.7		10.5	8.3		8.1			90
95	18.8	15.7	14.2	16.9	13.4	10.9	12.9	10.4	8.3	10.2	8.1		7.7			95
100	17.6	15.3	14.1	16.3	12.8	10.7	12.5	10.0	8.1	9.8	7.8		7.4	6.1		100
110	13.6	14.8	13.9	15.0	12.0	10.2	11.6	9.4	7.5	9.1	7.3	5.8	7.1	5.8		110
120	10.7	12.0	13.3	12.1	11.3	9.9	10.9	8.7	7.2	8.5	6.7	5.4	6.6	5.4		120
130	8.0	9.1		9.6	10.6	9.5	10.0	8.0	6.9	8.0	6.2	5.1	6.2	4.9	4.0	130
140	5.9			7.5	8.8		8.6	7.6	6.7	7.3	5.9	4.9	5.9	4.6	3.7	140
150				5.7	6.8		7.0	7.2	6.5	6.7	5.5	4.8	5.4	4.2	3.4	150
160				4.0	4.8		5.4	6.5	6.4	5.9	5.2	4.6	4.9	3.9	3.3	160
170							4.0	4.9		4.7	4.9	4.4	4.4	3.8	3.1	170
180										3.4	4.5		3.9	3.4	3.1	180
190											4.2			3.2	3.0	190
200											3.9			3.0	2.8	200

This information is not for crane operation. Operator must refer to the in-cab information for crane operation. Rated lifting capacities shown on fully extended outriggers do not exceed 85% of the tipping loads.

77,161 lb Counterweight – Fully Extended Outriggers – 360° Rotation (All Capacities Are Listed In Thousand Pounds)															
208.0 ft Main Boom Length															
Radius (ft)	43.3 ft Offset Fly			63.0 ft Offset Fly			82.7 ft Offset Fly			102.4 ft Offset Fly			122.0 ft Offset Fly		Radius (ft)
	0°	20°	40°	0°	20°	40°	0°	20°	40°	0°	20°	40°	0°	20°	
45	15.0														45
50	15.0			11.5											50
55	15.0			11.5			8.8								55
60	15.0			11.5			8.8			7.1					60
65	15.0	14.8		11.5			8.8			7.1			5.5		65
70	15.0	14.3		11.5			8.8			7.1			5.5		70
75	15.0	13.9		11.5	11.4		8.8			7.1			5.5		75
80	14.9	13.6	12.5	11.5	11.2		8.8			7.1			5.5		80
85	14.8	13.2	12.1	11.5	10.8		8.8	8.8		7.1			5.5		85
90	14.3	12.9	12.0	11.5	10.5		8.8	8.7		7.1			5.5		90
95	13.9	12.6	11.7	11.5	10.2		8.8	8.5		7.1			5.5		95
100	13.5	12.2	11.4	11.4	9.9	9.2	8.8	8.3		7.1	6.6		5.5		100
110	12.7	11.6	10.9	10.7	9.5	8.7	8.8	7.8	7.1	7.1	6.4		5.5	4.6	110
120	12.1	11.0	10.5	10.1	9.0	8.3	8.5	7.4	6.8	7.1	6.1		5.4	4.6	120
130	10.8	10.4	10.0	9.6	8.6	8.0	8.2	7.1	6.6	6.9	5.8	5.3	5.3	4.4	130
140	8.7	9.6	9.6	8.6	8.3	7.6	7.7	6.8	6.3	6.4	5.4	5.1	5.1	4.3	140
150	6.8	8.2	8.6	7.3	8.0	7.4	7.2	6.4	6.1	6.1	5.2	4.9	5.0	4.1	150
160	5.2	6.4	7.1	5.8	7.3	7.2	6.5	6.1	5.9	5.7	5.0	4.6	4.8	3.9	160
170	3.8	4.7	5.4	4.3	5.6	6.9	4.9	6.0	5.5	4.9	4.9	4.4	4.6	3.8	170
180		3.4	3.9	2.8	4.4	5.3	3.6	5.2	5.4	3.7	4.5	4.3	3.7	3.6	180
190					3.2	3.8				4.1	4.9	2.6	4.2	4.1	190
200								2.9	4.0				3.9		200
210									2.9				3.7	2.9	210

This information is not for crane operation. Operator must refer to the in-cab information for crane operation. Rated lifting capacities shown on fully extended outriggers do not exceed 85% of the tipping loads.

77,161 lb Counterweight – Fully Extended Outriggers – 360° Rotation (All Capacities Are Listed In Thousand Pounds)														
223.1 ft Main Boom Length														
Radius (ft)	43.3 ft Offset Fly			63.0 ft Offset Fly			82.7 ft Offset Fly			102.4 ft Offset Fly			122.0 ft Offset Fly	Radius (ft)
	0°	20°	40°	0°	20°	40°	0°	20°	40°	0°	20°	40°	0°	
50	13.0													50
55	13.0			10.1										55
60	13.0			10.1										60
65	13.0	13.0		10.1			7.9			6.2				65
70	13.0	13.0		10.1			7.9			6.2			5.1	70
75	13.0	12.9		10.1			7.9			6.2			5.1	75
80	13.0	12.7	11.8	10.1	10.1		7.9			6.2			5.1	80
85	13.0	12.4	11.5	10.1	10.1		7.9			6.2			5.1	85
90	13.0	12.0	11.1	10.1	9.8		7.9			6.2			5.1	90
95	12.8	11.7	10.9	10.1	9.6		7.9	7.9		6.2			5.1	95
100	12.5	11.4	10.7	10.1	9.4	8.5	7.9	7.8		6.2			5.1	100
110	11.8	10.7	10.2	10.0	8.9	8.2	7.9	7.3		6.2	6.0		5.1	110
120	11.3	10.2	9.8	9.4	8.5	7.9	7.9	7.0	6.6	6.2	5.7		5.1	120
130	10.5	9.7	9.3	8.9	8.0	7.5	7.5	6.7	6.2	6.2	5.6		5.1	130
140	8.4	9.3	9.0	8.5	7.6	7.2	7.2	6.3	5.9	6.0	5.2		4.9	140
150	6.5	8.0	8.2	7.4	7.3	7.0	6.8	6.1	5.6	5.8	5.0	4.5	4.8	150
160	4.9	6.2	7.1	5.8	6.8	6.7	6.0	5.9	5.5	5.3	4.8	4.4	4.5	160
170	3.4	4.7	5.4	4.3	5.8	6.4	4.5	5.5	5.3	4.7	4.4	4.2	4.2	170
180		3.4	3.9		4.5	5.3	3.3	4.9	5.1	3.4	4.3	4.1	3.4	180
190					3.1	4.0		3.9	4.8		4.0	3.9	2.6	190
200						2.7		2.7	4.0			3.7		200
210									2.9			3.5		210

This information is not for crane operation. Operator must refer to the in-cab information for crane operation. Rated lifting capacities shown on fully extended outriggers do not exceed 85% of the tipping loads.

51,808 lb Counterweight – Fully Extended Outriggers – 360° Rotation (All Capacities Are Listed In Thousand Pounds)													
43.3 ft Main Boom Length				111.9 ft Main Boom Length			208.0 ft Main Boom Length			223.1 ft Main Boom Length			Radius (ft)
Radius (ft)	17.7 ft Offset Fly			17.7 ft Offset Fly			17.7 ft Offset Fly			17.7 ft Offset Fly			
	0°	20°	40°	0°	20°	40°	0°	20°	40°	0°	20°	40°	
10	104.2												10
12	97.5	66.3											12
14	91.6	63.8											14
16	86.4	61.3											16
18	81.9	59.2	48.1										18
20	77.7	57.3	47.0	85.3									20
25	69.2	53.2	44.8	85.3									25
30	62.3	49.8	43.1	84.7	60.8	47.3							30
35	56.7	47.0	41.7	74.5	58.5	46.3							35
40	51.6	44.0	40.2	62.0	56.1	45.3							40
45	46.6	41.3		52.3	53.6	44.5							45
50	42.1			45.7	48.3	43.6	23.2			20.3			50
55				39.5	41.9	41.0	22.3	20.7	19.9	20.0	19.1		55
60				33.1	35.1	36.4	21.4	19.9	19.3	19.5	18.4	17.7	60
65				27.6	29.4	30.5	20.6	19.3	18.6	18.8	17.7	17.1	65
70				23.2	24.7	25.8	19.9	18.6	18.1	18.2	17.2	16.5	70
75				19.4	20.6	21.7	19.2	18.0	17.5	17.6	16.7	16.0	75
80				16.0	17.2	18.2	18.6	17.5	16.8	17.1	16.2	15.6	80
85				13.2	14.5	15.0	17.9	17.0	16.3	16.6	15.7	15.2	85
90				11.0	12.0	12.4	15.8	16.3	16.0	15.7	15.3	14.9	90
95				8.9	9.7	10.1	13.7	14.8	14.9	14.2	14.4	14.6	95
100				7.0	7.7	7.9	11.8	12.9	13.3	12.2	13.0	13.7	100
110				4.1	4.5		8.6	9.5	9.9	9.0	9.8	10.4	110
120							6.1	6.6	7.1	6.4	7.1	7.6	120
130							4.0	4.4	4.9	4.2	4.9	5.4	130

This information is not for crane operation. Operator must refer to the in-cab information for crane operation. Rated lifting capacities shown on fully extended outriggers do not exceed 85% of the tipping loads.

51,808 lb Counterweight – Fully Extended Outriggers – 360° Rotation (All Capacities Are Listed In Thousand Pounds)																
43.3 ft Main Boom Length																
Radius (ft)	43.3 ft Offset Fly			63.0 ft Offset Fly			82.7 ft Offset Fly			102.4 ft Offset Fly			122.0 ft Offset Fly			Radius (ft)
	0°	20°	40°	0°	20°	40°	0°	20°	40°	0°	20°	40°	0°	20°	40°	
10	39.7															10
12	39.7			35.1												12
14	39.0			34.3			22.9									14
16	37.2			33.3			22.9									16
18	35.4			32.3			22.9			14.1						18
20	33.7			31.4			22.9			14.1			10.1			20
25	30.4	24.5		29.2			22.9			14.1			10.1			25
30	27.6	22.5		27.1			21.9			14.1			10.1			30
35	25.2	21.0		24.9			20.2			14.1			10.1			35
40	23.2	19.7	17.3	22.9	18.8		18.8			14.1			10.1			40
45	21.5	18.5	16.5	21.3	17.6		17.4			13.9			10.1			45
50	20.1	17.6	15.9	19.9	16.3		16.2			13.2			10.0			50
55	18.8	16.8	15.4	18.4	15.1	12.7	15.1	12.9		12.4			9.7			55
60	17.7	16.0	15.0	16.9	14.1	12.0	14.2	12.2		11.8			9.2			60
65	16.7	15.3	14.8	15.6	13.1	11.5	13.3	11.1		11.1			8.9			65
70	15.9	14.9		14.4	12.4	11.0	12.5	10.4		10.4			8.4			70
75	15.3	14.6		13.3	11.7	10.5	11.6	9.8		9.9	8.3		8.0			75
80				12.4	11.1	10.1	10.6	9.1		9.3	7.8		7.6	6.7		80
85				11.5	10.4	9.7	10.0	8.6	7.7	8.4	7.3		7.3	6.4		85
90				10.7	10.0		9.3	8.1	7.4	7.9	6.8		7.0	5.9		90
95							8.6	7.7	7.1	7.4	6.4		6.5	5.5		95
100							8.0	7.4	6.8	6.9	6.1		6.0	5.2		100
110							7.2	6.7	6.4	6.1	5.4	5.0	5.2	4.7		110
120										5.4	5.0	4.6	4.6	4.1	3.7	120
130										4.7	4.5	4.2	4.1	3.8	3.3	130
140													3.5	3.5	3.2	140
150													3.1	3.1	3.0	150

This information is not for crane operation. Operator must refer to the in-cab information for crane operation. Rated lifting capacities shown on fully extended outriggers do not exceed 85% of the tipping loads.

51,808 lb Counterweight – Fully Extended Outriggers – 360° Rotation (All Capacities Are Listed In Thousand Pounds)																
111.9 ft Main Boom Length																
Radius (ft)	43.3 ft Offset Fly			63.0 ft Offset Fly			82.7 ft Offset Fly			102.4 ft Offset Fly			122.0 ft Offset Fly			Radius (ft)
	0°	20°	40°	0°	20°	40°	0°	20°	40°	0°	20°	40°	0°	20°	40°	
20	39.3															20
25	36.8			28.9												25
30	34.6			28.8			19.6			12.6						30
35	32.4			28.0			19.6			12.6			9.0			35
40	30.7	22.4		27.0			19.6			12.6			9.0			40
45	29.0	21.4		25.8			19.4			12.6			9.0			45
50	27.4	20.5		24.6			18.9			12.6			9.0			50
55	26.1	19.7	16.5	23.5	17.7		18.1			12.6			9.0			55
60	24.9	19.1	16.0	22.5	17.1		17.3			12.6			9.0			60
65	23.7	18.4	15.7	21.5	16.4	12.8	16.6	12.6		12.6			9.0			65
70	22.7	17.9	15.4	20.5	15.9	12.5	15.9	12.1		12.1			9.0			70
75	21.6	17.4	15.1	19.7	15.4	12.2	15.3	11.7		11.7			8.8			75
80	20.0	16.9	14.9	19.0	14.9	11.8	14.6	11.4		11.4	9.0		8.6			80
85	17.1	16.6	14.6	18.1	14.4	11.5	13.9	11.0		11.0	8.6		8.4			85
90	14.8	16.1	14.4	16.2	13.9	11.1	13.4	10.7		10.5	8.3		8.1			90
95	12.6	14.8	14.2	14.3	13.4	10.9	12.9	10.4	8.3	10.2	8.1		7.7			95
100	10.7	13.1	13.7	12.4	12.8	10.7	12.5	10.0	8.1	9.8	7.8		7.4	6.1		100
110	7.5	9.6	10.5	9.2	11.7	10.2	10.8	9.4	7.5	9.1	7.3	5.8	7.1	5.8		110
120	5.1	6.5	7.1	6.6	9.0	9.7	8.3	8.7	7.2	8.4	6.7	5.4	6.6	5.4		120
130	3.1	4.0		4.6	6.5	7.8	6.0	8.0	6.9	6.9	6.2	5.1	6.2	4.9	4.0	130
140					4.3		4.1	6.3	6.7	5.1	5.9	4.9	5.4	4.6	3.7	140
150								4.5	5.7	3.5	5.3	4.8	4.2	4.2	3.4	150
160								2.6	4.0		4.4	4.5	2.7	3.9	3.3	160
170												4.0		3.8	3.1	170
180															3.1	180

This information is not for crane operation. Operator must refer to the in-cab information for crane operation. Rated lifting capacities shown on fully extended outriggers do not exceed 85% of the tipping loads.

51,808 lb Counterweight – Fully Extended Outriggers – 360° Rotation (All Capacities Are Listed In Thousand Pounds)													
208.0 ft Main Boom Length													
Radius (ft)	43.3 ft Offset Fly			63.0 ft Offset Fly			82.7 ft Offset Fly			102.4 ft Offset Fly		122.0 ft Offset Fly	Radius (ft)
	0°	20°	40°	0°	20°	40°	0°	20°	40°	0°	20°	0°	
45	15.0												45
50	15.0			11.5									50
55	15.0			11.5			8.8						55
60	15.0			11.5			8.8			7.1			60
65	15.0	14.8		11.5			8.8			7.1		5.5	65
70	15.0	14.3		11.5			8.8			7.1		5.5	70
75	15.0	13.9		11.5	11.4		8.8			7.1		5.5	75
80	14.9	13.6	12.5	11.5	11.2		8.8			7.1		5.5	80
85	14.8	13.2	12.1	11.5	10.8		8.8	8.8		7.1		5.5	85
90	14.3	12.9	12.0	11.5	10.5		8.8	8.7		7.1		5.5	90
95	13.9	12.6	11.7	11.5	10.2		8.8	8.5		7.1		5.5	95
100	13.3	12.2	11.4	11.4	9.9	9.2	8.8	8.3		7.1	6.6	5.5	100
110	10.6	11.6	10.9	10.7	9.5	8.7	8.8	7.8	7.1	7.1	6.4	5.5	110
120	8.2	9.9	10.4	8.6	9.0	8.3	8.5	7.4	6.8	7.1	6.1	5.4	120
130	5.8	7.6	8.8	6.4	8.3	8.0	7.1	7.1	6.6	6.9	5.8	5.3	130
140	4.0	5.5	6.7	4.7	6.5	7.5	5.4	6.8	6.3	5.4	5.4	5.0	140
150		3.5	4.7	3.0	4.9	6.2		5.9	6.1	3.8	5.2	4.0	150
160			2.8		3.4	4.5		4.5	5.7		4.8		160
170						3.0		3.2	4.7		3.8		170
180									3.4				180

This information is not for crane operation. Operator must refer to the in-cab information for crane operation. Rated lifting capacities shown on fully extended outriggers do not exceed 85% of the tipping loads.

51,808 lb Counterweight – Fully Extended Outriggers – 360° Rotation (All Capacities Are Listed In Thousand Pounds)												
223.1 ft Main Boom Length												
Radius (ft)	43.3 ft Offset Fly			63.0 ft Offset Fly			82.7 ft Offset Fly			102.4 ft Offset Fly	122.0 ft Offset Fly	Radius (ft)
	0°	20°	40°	0°	20°	40°	0°	20°	40°	0°	0°	
50	13.0											50
55	13.0			10.1								55
60	13.0			10.1								60
65	13.0	13.0		10.1			7.9			6.2		65
70	13.0	13.0		10.1			7.9			6.2	5.1	70
75	13.0	12.9		10.1			7.9			6.2	5.1	75
80	13.0	12.7	11.8	10.1	10.1		7.9			6.2	5.1	80
85	13.0	12.4	11.5	10.1	10.1		7.9			6.2	5.1	85
90	13.0	12.0	11.1	10.1	9.8		7.9			6.2	5.1	90
95	12.8	11.7	10.9	10.1	9.6		7.9	7.9		6.2	5.1	95
100	12.4	11.4	10.7	10.1	9.4	8.5	7.9	7.8		6.2	5.1	100
110	10.4	10.7	10.2	10.0	8.9	8.2	7.9	7.3		6.2	5.1	110
120	7.8	9.7	9.8	8.8	8.5	7.9	7.9	7.0	6.6	6.2	5.1	120
130	5.6	7.3	8.4	6.6	8.0	7.5	6.8	6.7	6.2	6.2	5.1	130
140	3.8	5.4	6.4	4.8	6.8	7.2	5.0	6.3	5.9	5.0	4.8	140
150		3.6	4.6	2.9	5.2	6.2	3.1	5.5	5.6	3.7	4.4	150
160			2.9		3.5	4.7		4.3	5.3			160
170						3.2		2.9	4.5			170

This information is not for crane operation. Operator must refer to the in-cab information for crane operation. Rated lifting capacities shown on fully extended outriggers do not exceed 85% of the tipping loads.

5519 (supersedes 5485) - 0208 - R4

Link-Belt Construction Equipment Company Lexington, Kentucky www.linkbelt.com

®Link-Belt is a registered trademark. Copyright 2008. We are constantly improving our products and therefore reserve the right to change designs and specifications.

ATC-3250

Link-Belt Cranes